

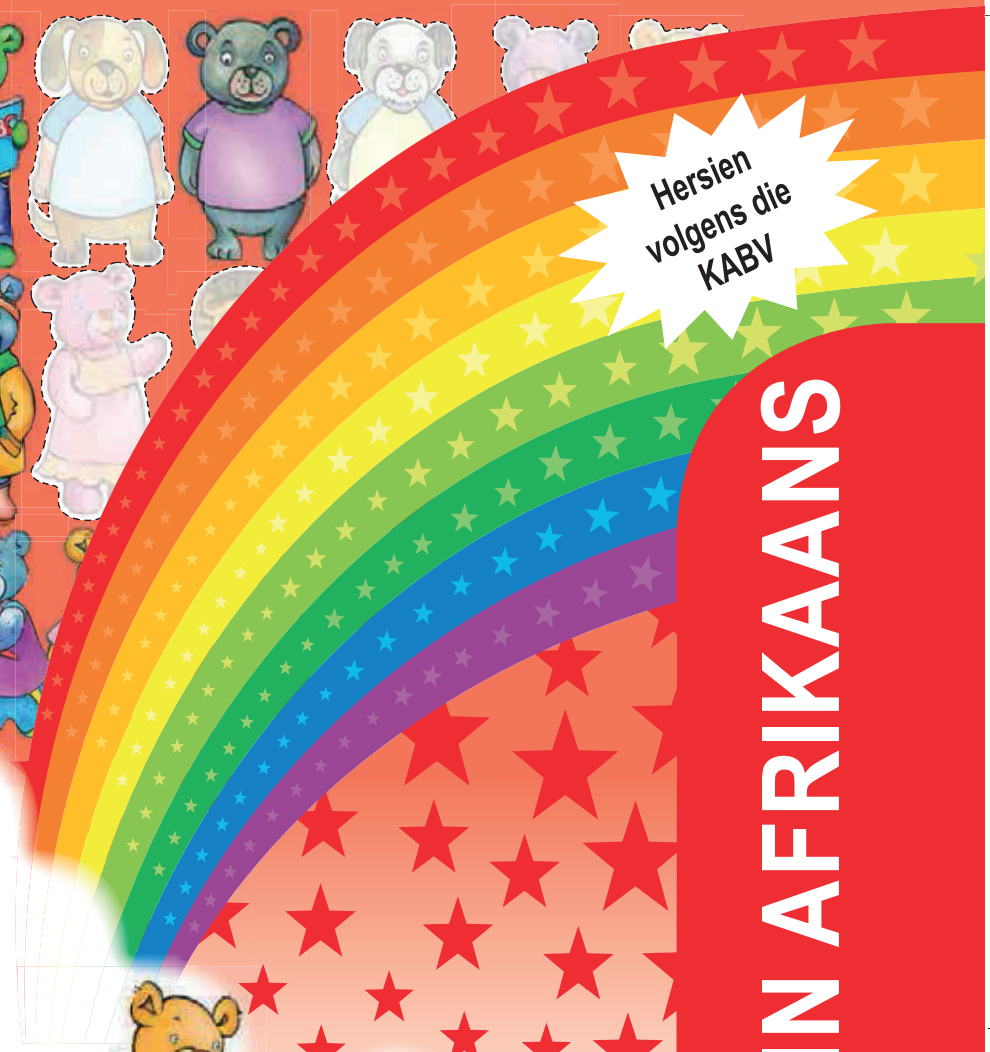

AFRIKAANS
 GRADE R – BOOK 1
 TERM 1
 ISBN 978-1-4315-0690-3
 THIS BOOK MAY NOT BE SOLD.
 11th Edition



Hersien
 volgens die
 KABV



Graad **R**
WERKBOEK 1

Naam: Klas:

 **basic education**
 Department:
 Basic Education
 REPUBLIC OF SOUTH AFRICA

WERKBOEK IN AFRIKAANS
 Boek
 —
 Kwartaal 1



Mev. Angie Motshekga,
Minister van Basiese
Onderwys



Dr. Reginah Mhaule,
Adjunkminister van
Basiese Onderwys

Hierdie Reënboog-Werkboeke vir die Resepsiejaar (Graad R) maak deel uit van die Departement Basiese Onderwys se strategie om Suid-Afrikaanse kinders se skoolprestasie 'n hupstoot te gee. Navorsing toon dat kinders wat voor Graad 1 aan stimulerende aktiwiteite blootgestel word, deur hul primêre en sekondêre skooljare heen akademies beter presteer. Daarom fokus die Departement so sterk op leer in Graad R.

Die Grondslagfase-kurrikulum verg dat Graad R-leerders die geleentheid moet ontvang om die vaardighede wat hul aanleer van lees, skryf en Wiskunde voorafgaan, te ontwikkel, en identifiseer die vaardighede wat hulle nodig het om die vaste opvoedkundige grondslag te verkry waarop hulle in Graad 1 en sal kan voortbou.

Die Graad R-Werkboeke is dus daarop gemik om kinders te help om die vaardighede en sleutelbegrippe te ontwikkel wat hulle nodig het om 'n stewige grondslag vir leer te vestig. Die boeke is propvol geleenthede vir kinders om die vaardighede wat hulle op formele skoolopleiding sal voorberei, te ontwikkel en in te oefen.

Voordat kinders formeel leer lees, het hulle nodig om te leer hoe om 'n boek vas te hou en die bladsye om te blaai. Hulle moet verstaan hoe boeke werk. Hulle moet die verhouding tussen die woorde en die prente in 'n boek leer ken, en beseft dat woorde op 'n bladsy uit klanke bestaan en betekenis het. Net so moet hulle, voordat hulle leer skryf, hul fyn motoriese koördinasie ontwikkel en begin oefen hoe om vorms op papier te maak. Van daar af moet hulle tot die vorming van letters oorgaan. Dit is juis hierdie vaardighede wat die Werkboeke wil ontwikkel.

Ons weet almal dat kinders nie teen dieselfde pas leer nie. Die Graad R-Werkboeke maak dit vir onderwysers moontlik om teen leerders se individuele pas te werk, en om waar nodig vorentoe en agtertoe in die boek te werk volgens elke kind se unieke ontwikkeling. Die aktiwiteite sal onderwysers ook help om struikelblokke te identifiseer wat kinders in hul leerproses mag ervaar, sodat sulke struikelblokke voorkom kan word voordat die kind sy of haar formele skoolloopbaan aanpak.

Die Werkboeke integreer die onderrig van Huistaal, Wiskunde en Lewensvaardigheid oor 20 temas heen. Jong leerders se belangstelling word op prettige, boeiende wyses vasgevang. Ons hoop dat u leerders dit sal geniet om die Werkboekaktiwiteite deur te werk namate hulle groei en leer, en dat u, as hul onderwyser, hul genot sal deel.



Alfabet

Aa

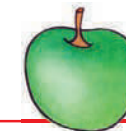

Bb



Cc



Dd



Ee



Ff



Gg



Hh



Ii



Jj



Kk



Ll



Mm



Nn



Oo



Pp



Qq

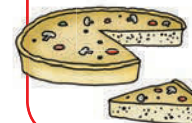

Rr



Ss



Tt



Uu



Vv

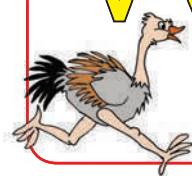

Ww



Xx



Yy

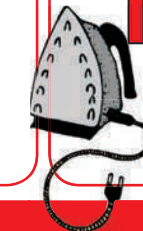

Zz



Graad R GEÏNTEGREERDE

- HUISTAAL
- WISKUNDE
- LEWENSWAARDIGHEID

W e r k b o e k

1	Alles oor my	2
2	In die klaskamer	12
3	My liggaam	22
4	Ek leef gesond	32
5	My maats	42



Die instruksies vir die uitknipsels is agter in die boek.



Aan die opvoeder:

Leerders moet genoeg geleentheid kry om aktiwiteite prakties te oefen voordat hulle die aktiwiteite skriftelik voltooi. Byvoorbeeld:

- Indien leerders die regte antwoorde moet omkring, word daar aanbeveel dat hulle eers 'n merker op die regte antwoorde moet plaas. U as opvoeder kan die antwoorde dan kontroleer en die leerders herhaaldelik die geleentheid gee om dit te oefen. Sodra leerders die aktiwiteit bemeester het, kan hulle dit skriftelik voltooi.
- Indien dit 'n "trek na"-opdrag is, laat die leerders dit eers met hulle vingers natrek voordat hulle dit skriftelik doen.

Let wel: Leerders verkeer in verskillende ontwikkelingsstadiums. Indien u leerders se fyn-motoriese vaardighede nog aandag geniet, word aanbeveel dat u leerders waar nodig die geleentheid gee om die betrokke aktiwiteite in hulle blanko A4-klaswerkboeke te oefen.



AFRIKAANS

Boek



Kwartaal 1



Alles oor my



Kwartaal I – Week I-5



Ek is in Graad R.





My naam is:

Blank space for writing a name.



Ons doen

Is jy 'n seun of 'n meisie?
Plak 'n merker op die regte woord.

Ek is 'n

seun.

seun



meisie

Ek is 'n

meisie.



Ons doen Teken 'n prent van jouself.

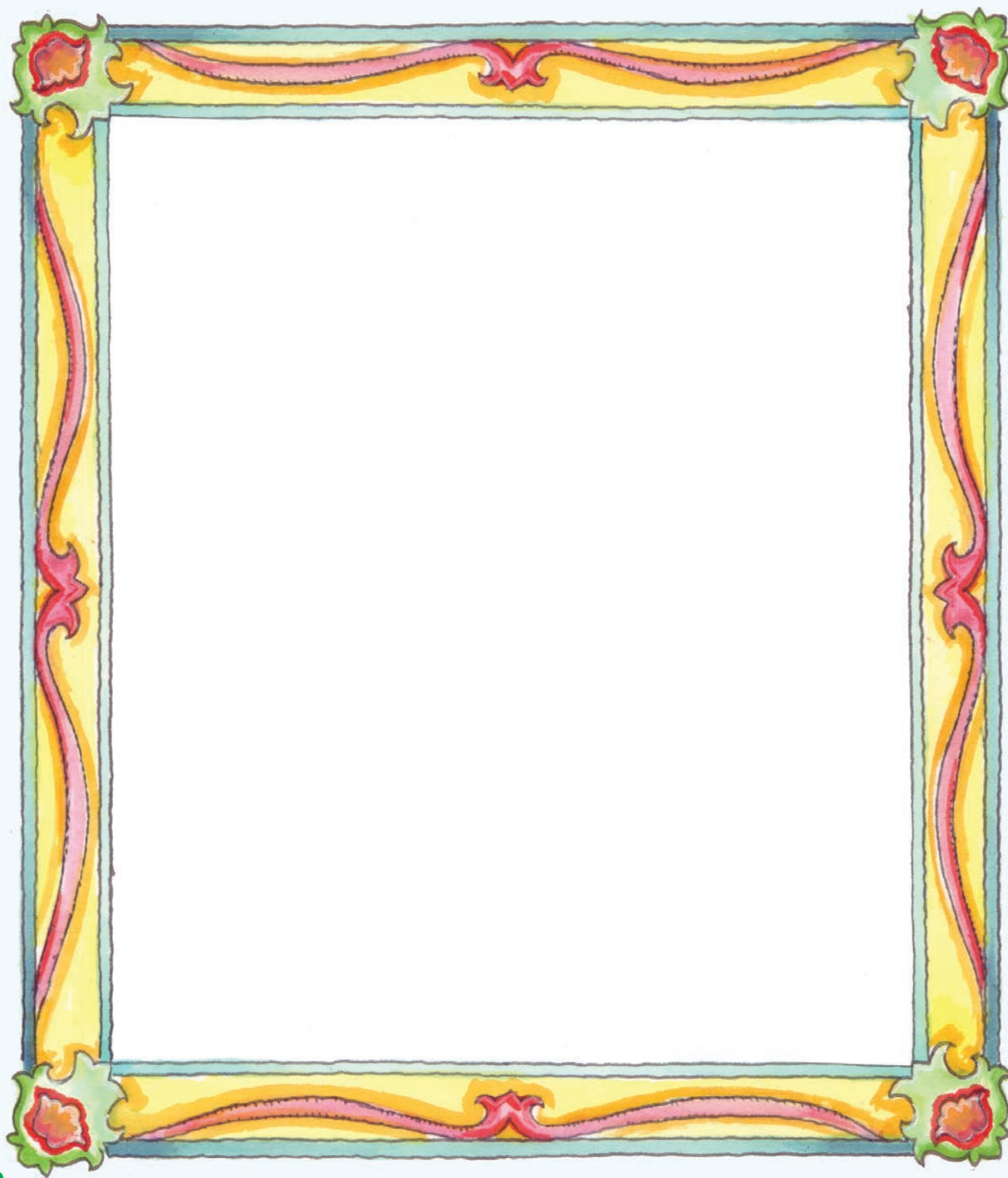

1.2



My naam is:

A large empty rectangular box with a blue and yellow dotted border, intended for writing the child's name.



Ons doen

Kleur die korrekte aantal kersies in om te wys hoe oud jy is.



Hoe oud is jy?

Ek is

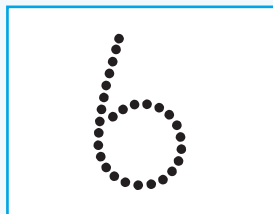

jaar oud.

Onderwyser: Teken

Empty rectangular box for the teacher's signature.

Datum

Empty rectangular box for the date.





Ons skryf

Plak die plakkertjies op die regte plekke.
Trek die lyne eers met jou vinger en dan met 'n stuk kryt na.

Plak die plakkertjies op die regte plekke.



Help die seun om sy fiets te kry.

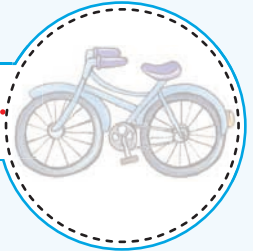
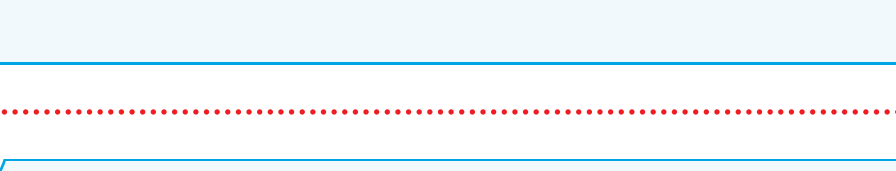
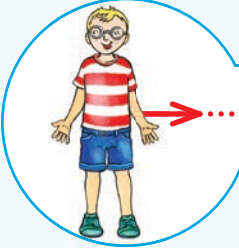

Help die meisie om die bal te skop.

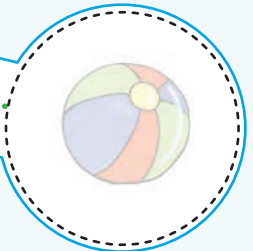
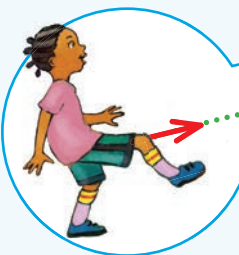

Trek die toutjie tot by die vlieër na.

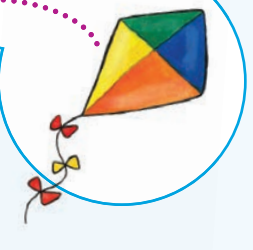
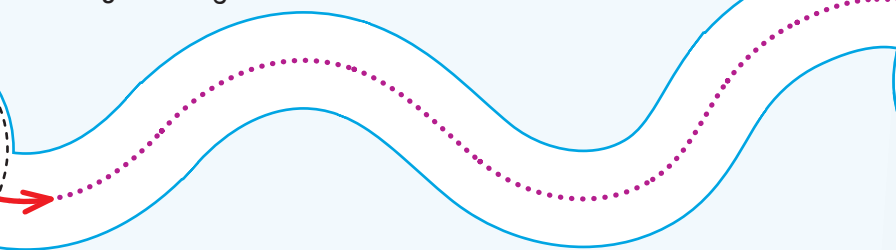

Bestuur die motor skool toe en weer terug huis toe.

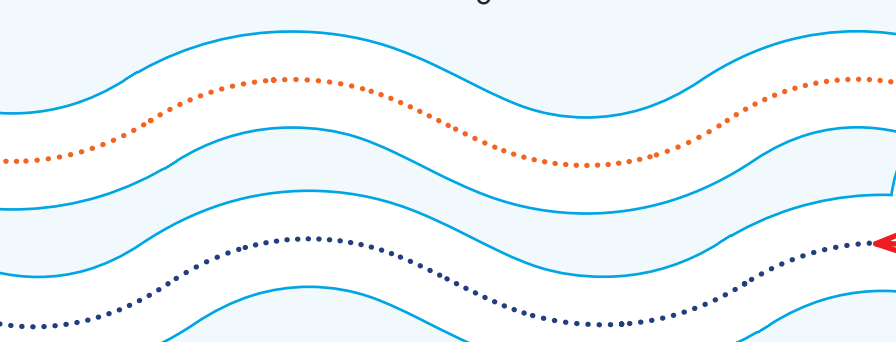
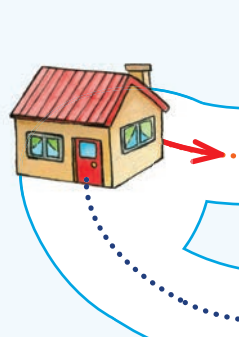

Vir bykomende oefening kan leerders hul lyne 'n paar keer met verskillende kleure natrek.



Hoeveel ek weeg

Ons skryf



kg

Hoe lank ek is

cm



Ons skryf

Trek 'n kruisie in die regte blok.

Die kleur van my oë

<input type="checkbox"/>		<input type="checkbox"/>	
	<input type="checkbox"/>		<input type="checkbox"/>

Die kleur van my hare



<input type="checkbox"/>	<input type="checkbox"/>	<input type="checkbox"/>	<input type="checkbox"/>	<input type="checkbox"/>





Ons doen

Plak 'n sterplakkertjie in om te wys wat jy graag doen.

Plak die
plakkertjies
op die regte
plekke.

Ek hou daarvan om:

te dans



'n storie te lees



met my maats te speel



met 'n bal te speel



dinge met blokkies te bou



te sing



1.6



Ons skryf

Teken 'n prentjie om te wys wat jy graag doen.



My naam is:

Onderwyser: Teken

Datum





My naam is:

Large empty rectangular box with a blue and yellow dotted border for writing a name.



Ons skryf





Kies die prentjies wat by mekaar pas.



1

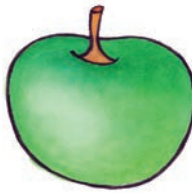
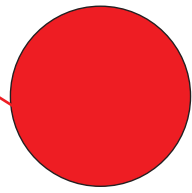



1





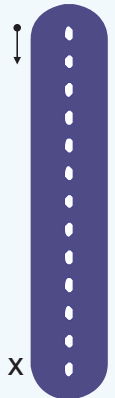

Ons tel

Omkring die voorwerp/item.
Klap jou hande een maal vir elke item wat jy sien.

Oefen die syfer 1.



2

In die klaskamer

Plak die plakkertjies op die regte plekke.



Ons skryf

Kyk na die prent en gesels oor alles wat die kinders doen.
Wat doen jy graag?

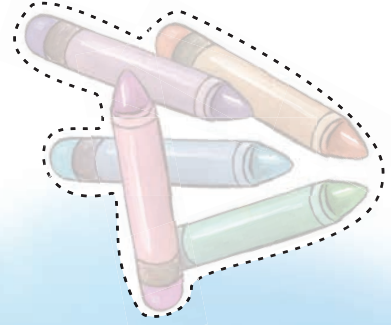



My naam is:

A large rectangular box with a dotted green border, intended for a child to write their name.



Onderwyser: Teken

Blank space for the teacher's signature.

Datum

Blank space for the date.



2.1



Ons skryf

Teken toutjies vir die ballonne.
Watter ballon het die kortste toutjie?
Watter ballon het die langste toutjie?

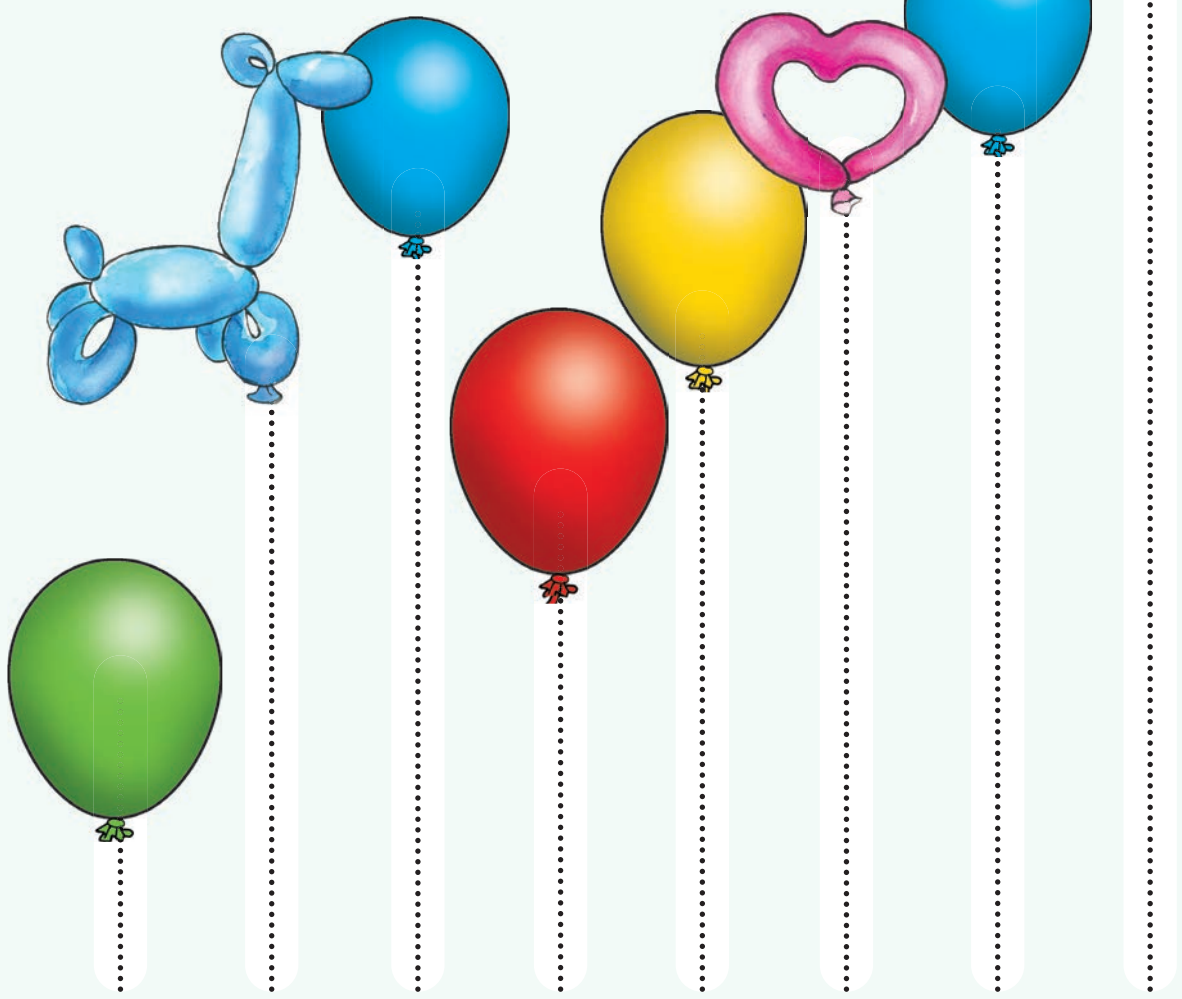
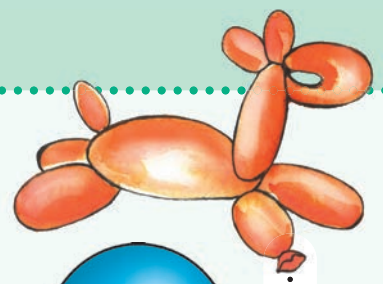

Kleur die ballonne rooi, geel, groen en blou in.

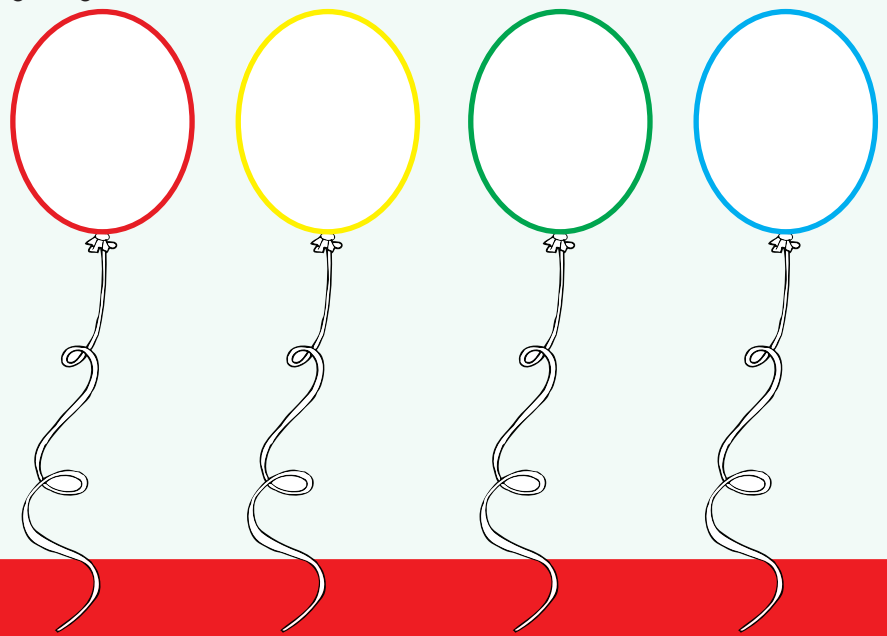



Ons skryf

Soek en omkring die gesiggies wat dieselfde gevoel as die eerste gesiggie wys.



Ons doen

Waarheen kyk hierdie seun? Moenie jou kop beweeg nie, maar beweeg jou oë totdat jy in dieselfde rigting as die seun kyk.

--	--	--	--





Ons tel

Omkring die blokke waarin daar 2 items is.
Klap jou hande twee maal elke keer wanneer jy 2 items sien.



Oefen die syfer 2.

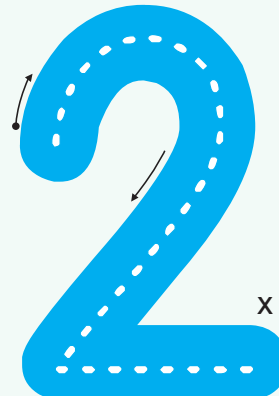
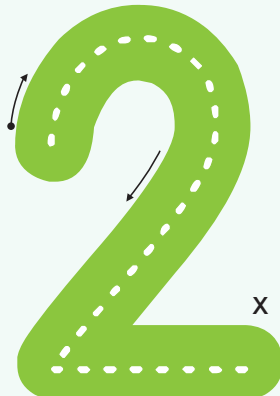
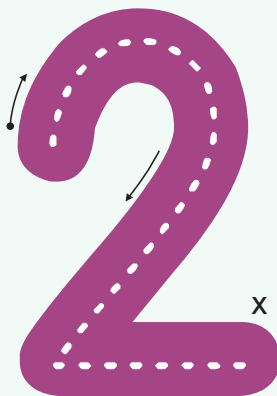

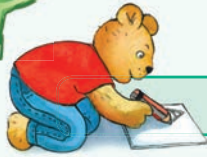

Ons skryf

Kleur 2 items in elke ry in.

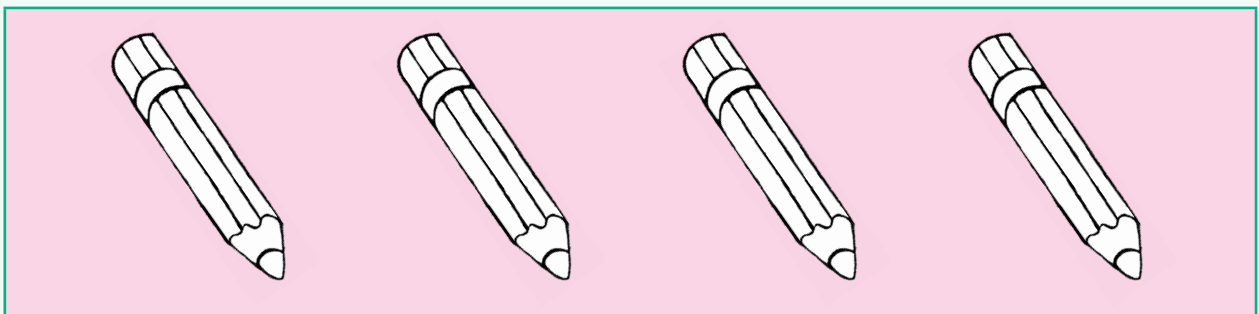
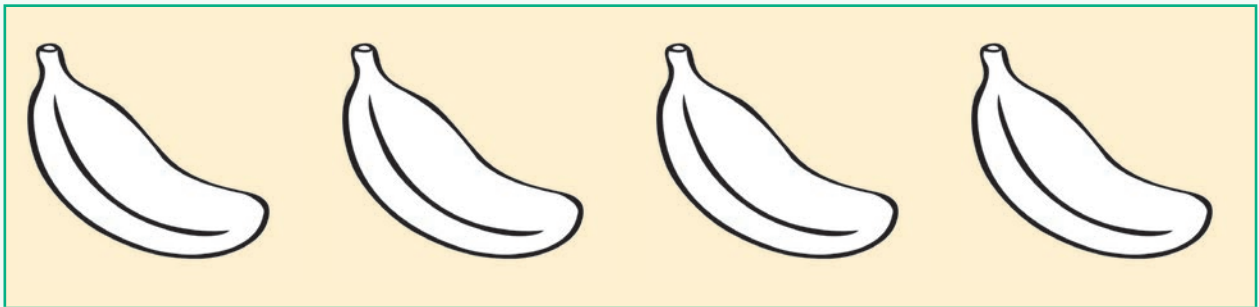
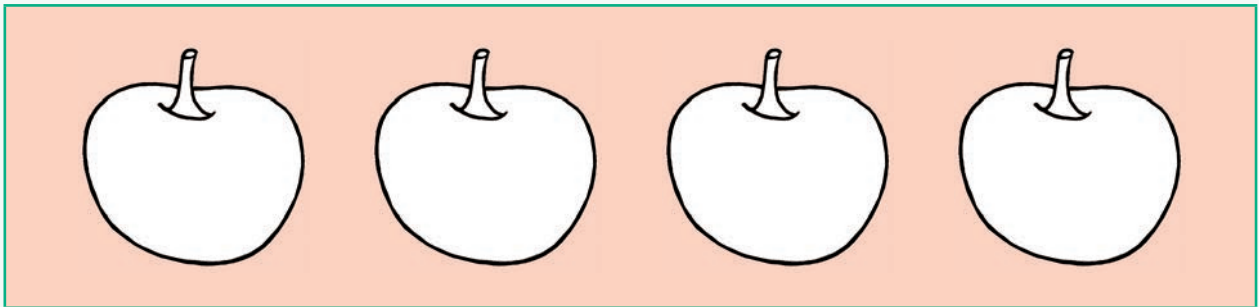
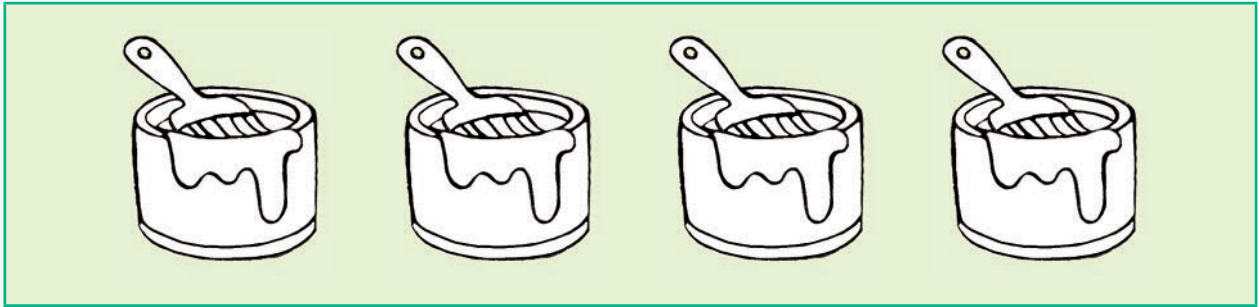

My naam is:

A large empty rectangular box with a dotted border, intended for writing a name.





Ons doen

Wat is daar in jou skoolsak?
Plak die plakkers in om die sak te pak.



uitveër



skerpmaker



kryt

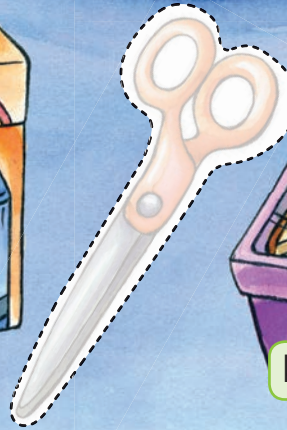

skêr



kosblik

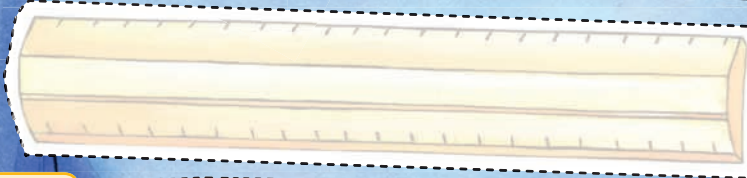

liniaal



potloodboksie

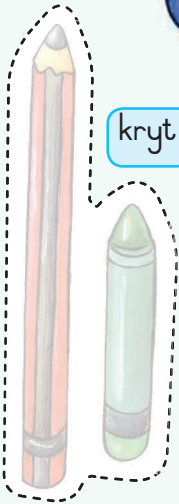

kryt

potlood



Ons skryf

Skryf jou naam
op die skoolsak.

Naam:

2.6





Ons skryf

Plak die plakkertjies op die regte plekke. Trek die lyne eers met jou vinger en dan met 'n stuk kryt na.

Plak die plakkertjies op die regte plekke.

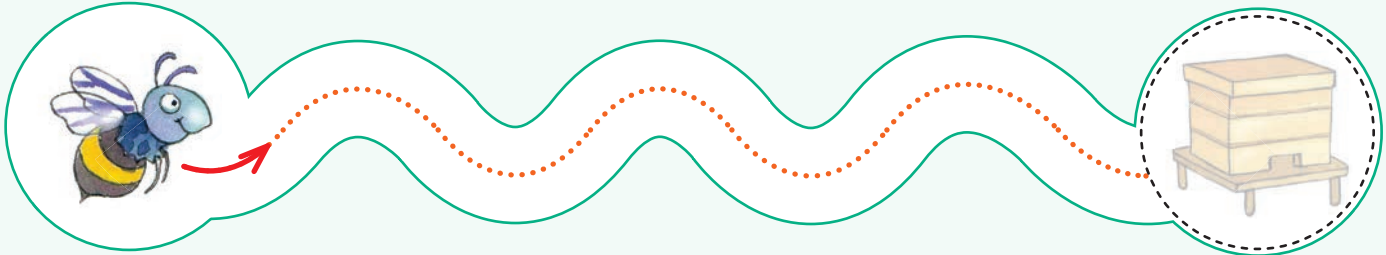
 Help die by om sy korf te kry.



 Help die padda om die dammetjie te kry.

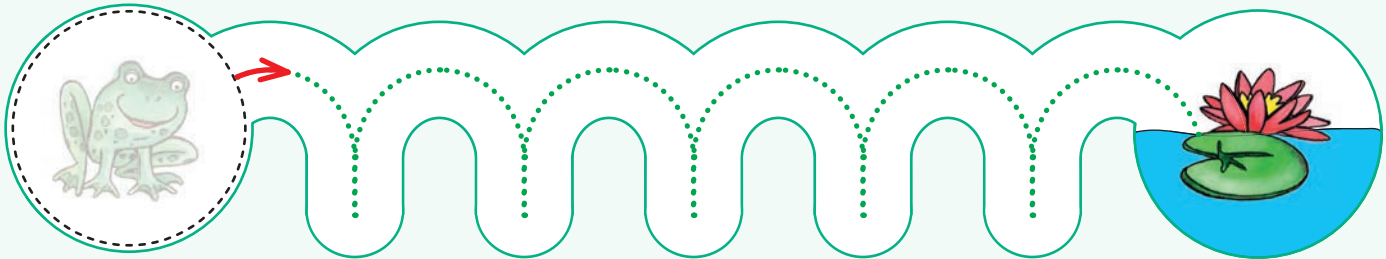

 Help die voël om sy nessie te kry.

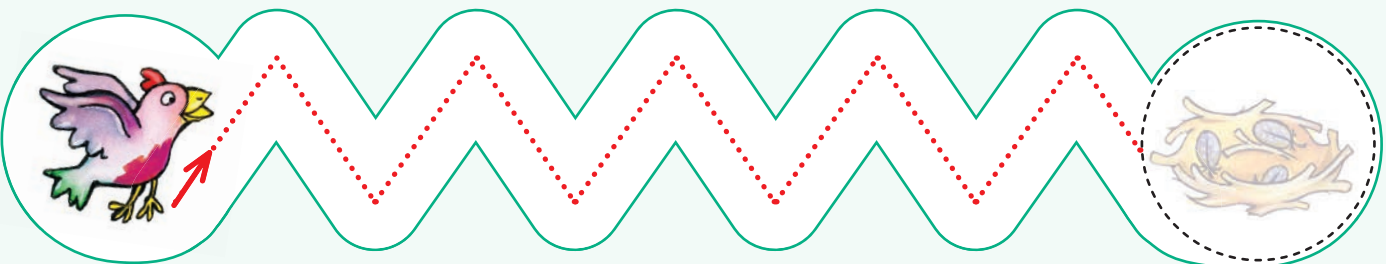

 Help die boot om by die eiland uit te kom.

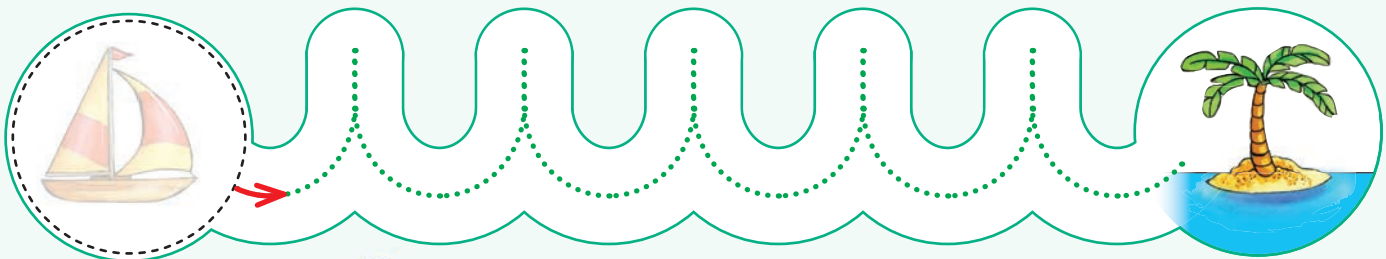

Vir bykomende oefening kan leerders hul lyne 'n paar keer met verskillende kleure natrek.



Ons doen

Plak 'n sterplakkertjie in om te wys wat jy graag by die skool doen.

Plak die plakkertjies op die regte plekke.

Ek hou daarvan om:

te verf



te teken



saam met 'n maat skool toe te stap



'n storie te lees



te tel



prente uit te knip



2.8



Ons skryf

Teken 'n prent om te wys wat jy graag by die skool doen.



My naam is:

Onderwyser: Teken

Datum



3

My liggaam



Ons praat

Kyk na die prent en gesels oor wat die kinders alles doen.

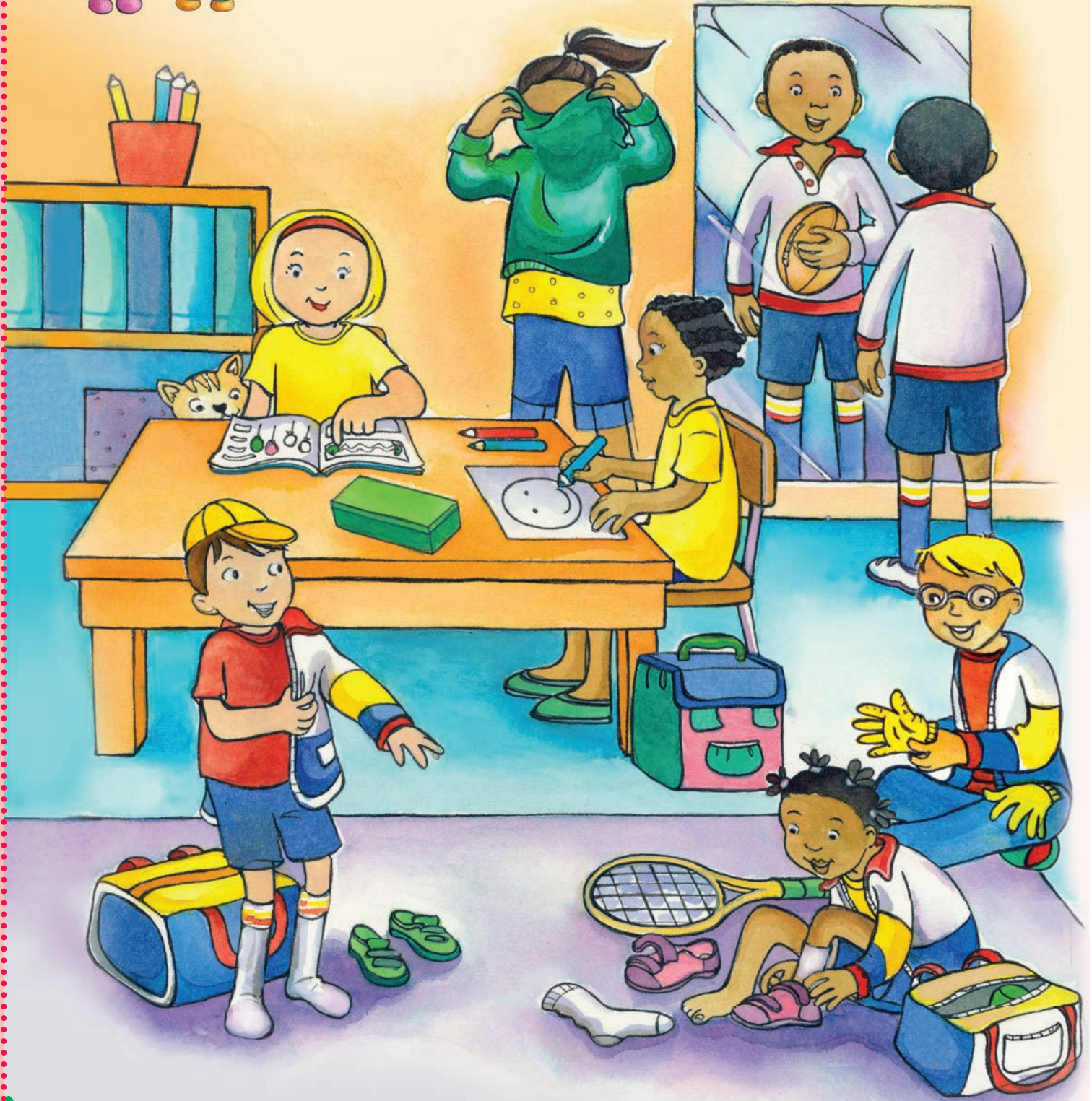

Plak die plakkertjies op die regte plekke.

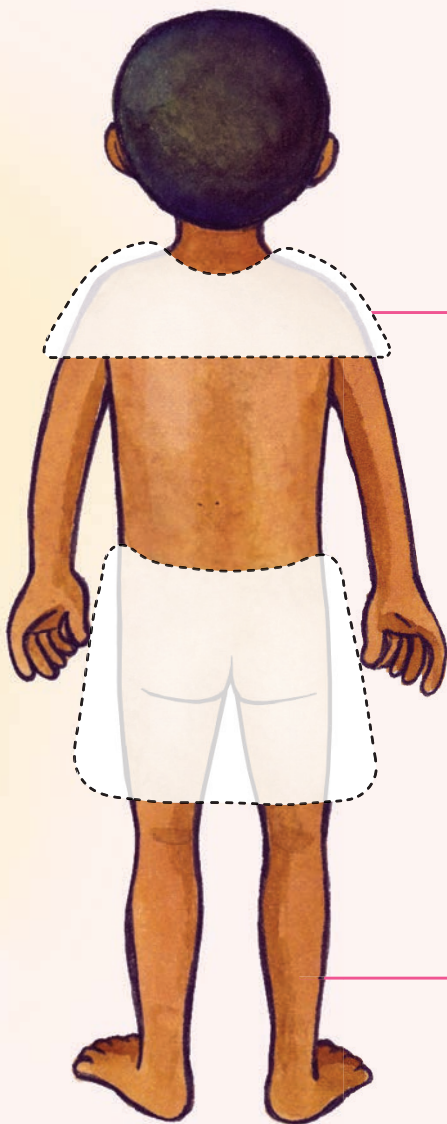

kop

skouer

arm

hand

knie

been

voet

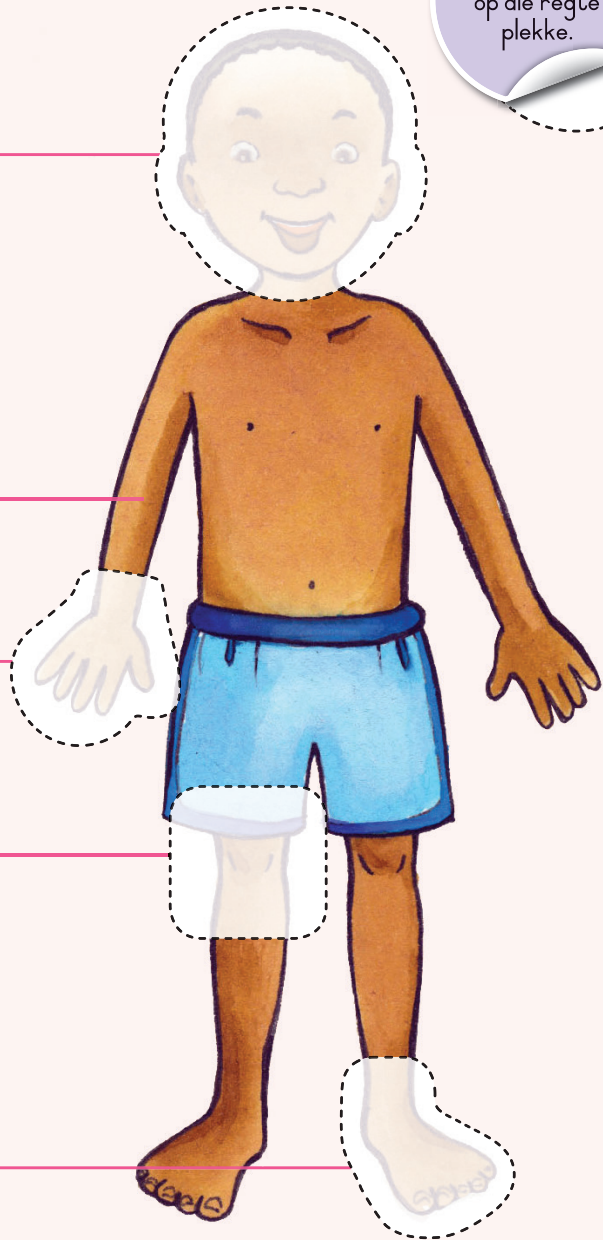

My naam is:



Ons praat

Wys na jou kop, skouers, knieë en tone.
Wys nou waar die seun in die prent se kop,
skouers, knieë en tone is.
Van watter liggaamsdele het jy net een?
Van watter liggaamsdele het jy twee?



Ons skryf

Wys na jou kop, arms, bene en lyf. Teken jouself.

Skryf jou naam en klap die ritme daarvan.



My naam is:





Ons skryf

Knip die arms en bene uit en plak hulle in om hierdie prentjie te voltooi. Kleur die prentjie dan in.

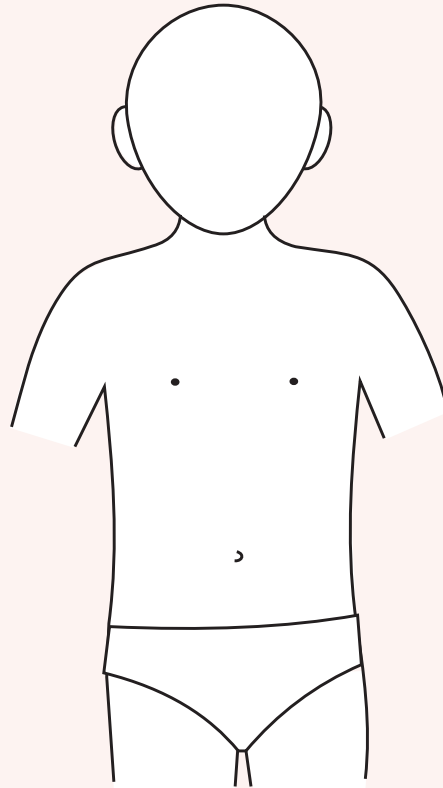
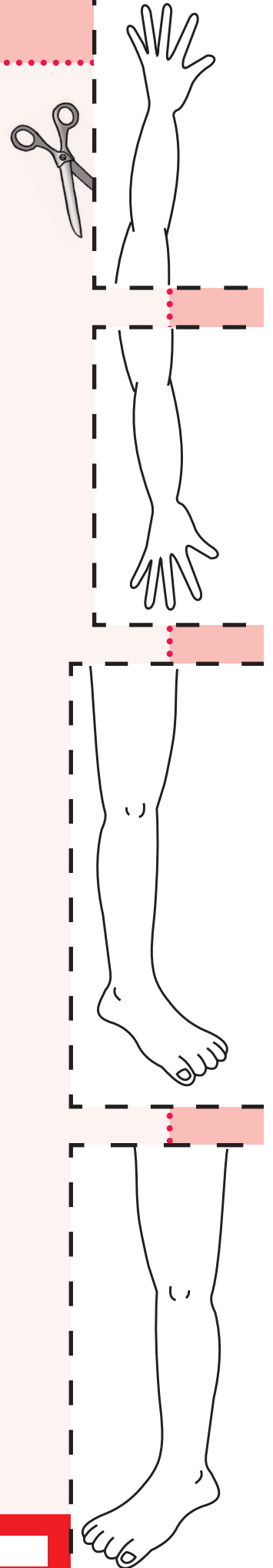

Ons sing



Klap, klap, klap!
 Klippertjie kappertjie
 kap, kap, kap.
 Mondjie
 happertjie
 hap, hap, hap.
 Voetjie skoppertjie
 handjie klappertjie.
 Happertjie
 skoppertjie
 klap, klap, klap.



Onderwyser: Teken

Datum



Ons doen

Staan soos die seun en die meisie in hierdie prente.
Wys eers jou regterhand en dan jou linkerhand.
Stamp jou regtervoet en dan jou linkervoet.





My naam is:

[Empty box for writing name]

meisie

voorkant



regterhand



linkerhand



regtervoet



linkervoet

[Empty box for teacher name]

[Empty box for date]

Plak die plakkertjies op die regte plekke.

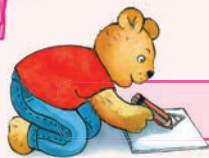

Ons skryf

Plak die plakkertjies op die regte plekke. Trek die lyne eers met jou vinger en dan met 'n stuk kryt na.



Help die baba om sy teddiebeer te kry.



Help die hond om sy been te kry.

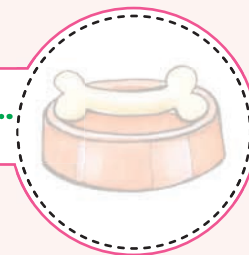
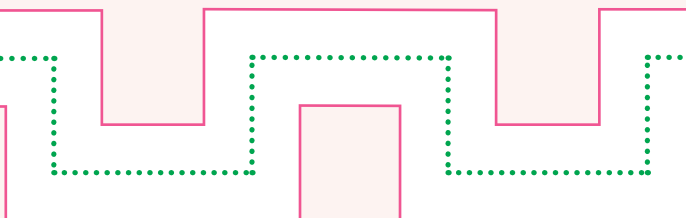

Help Anita om haar boek te kry.

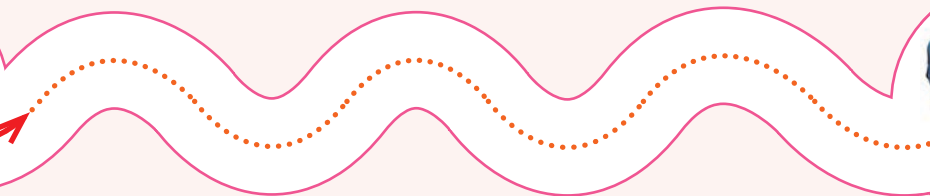

Help die baba om na haar ma toe te kruip.



Vir bykomende oefening kan leerders hul lyne 'n paar keer met verskillende kleure natrek.

3.6

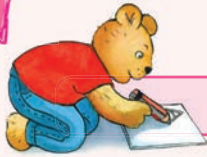

Ons skryf

Trek een van jou handjies na.

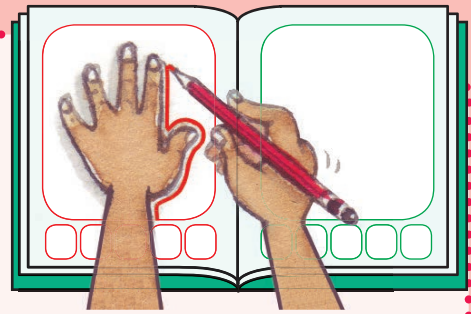

Gebruik dan lipstiffie of verf om jou vingerafdrukke in die raampies te maak.

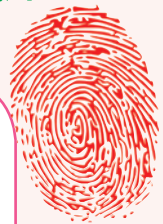

Onderwyser: Teken

Datum



Ons doen

Doen wat hierdie kinders doen.

staan met jou
hande
op jou
heupe



raak aan jou knieë



raak aan die
teenoorgestelde
voet



raak aan die
teenoorgestelde
skouer



vou jou arms



raak aan jou maag



raak aan jou neus



raak aan jou tone



steek
albei jou
hande in
die lug



raak aan
jou kop



raak aan jou
skouers



steek jou arm uit





My naam is:

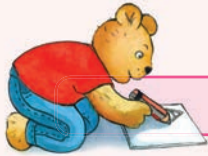

Ons skryf

Omkring in elke ry die prentjie wat nie pas nie.
Sê vir jou maat waarom die prentjie nie pas nie.

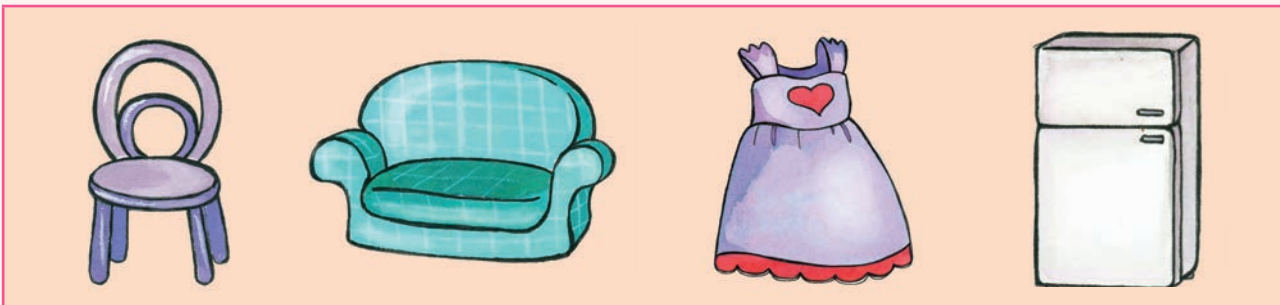
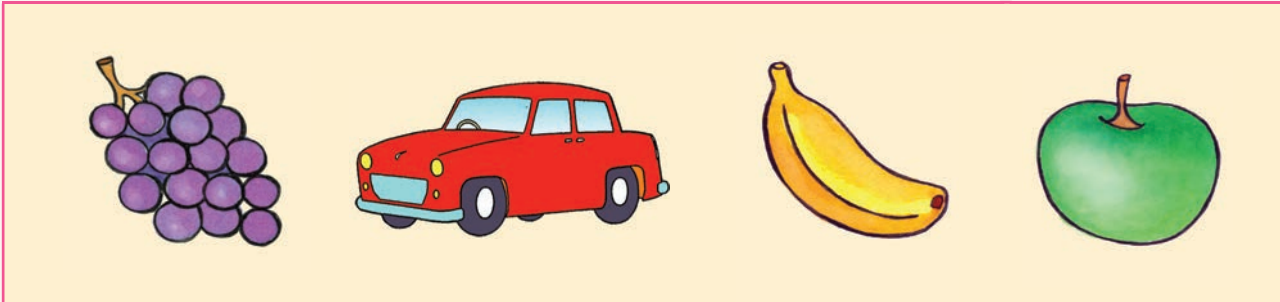
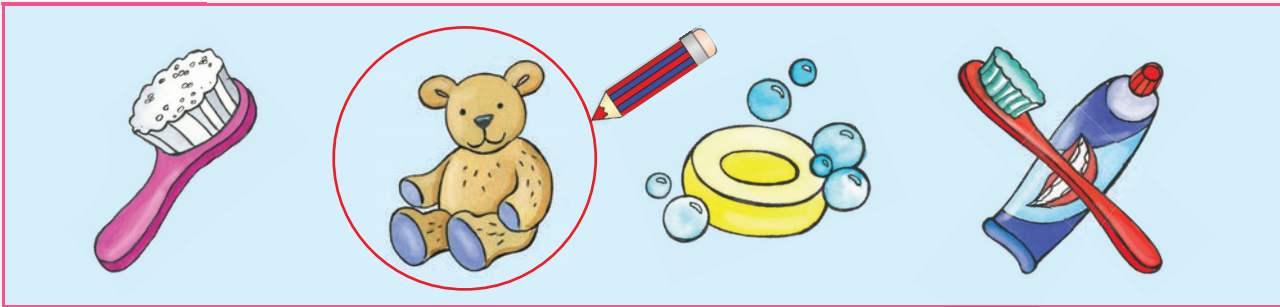



Ek leef gesond



Plak die plakkertjies op die regte plekke.





Ons praat

Kyk na die prent en sê wat elke kind doen om skoon te bly.

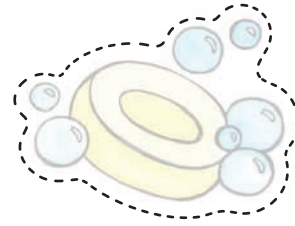

My naam is:

A large empty rectangular box with a yellow border for writing the child's name.

Onderwyser: Teken

Blank space for the teacher's signature.

Datum

Blank space for the date.



Ons skryf

Trek die lyne na om uit te vind wat hierdie kinders doen om skoon te bly.

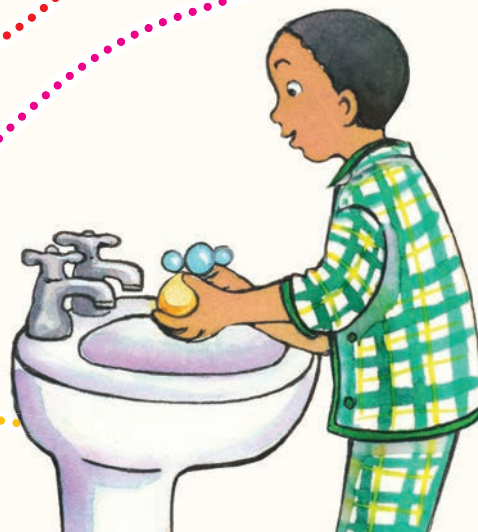
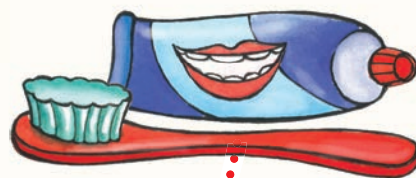

4.2



Ons skryf

Teken 'n prentjie om te wys wat jy doen om skoon te bly.



My naam is:

Onderwyser: Teken

Datum





My naam is:



Ons skryf

Kan jy die tandepasta in hierdie prentjie kry?
Kleur dit rooi in. Trek die lyne na en tel hoeveel
ander items jy kan sien.

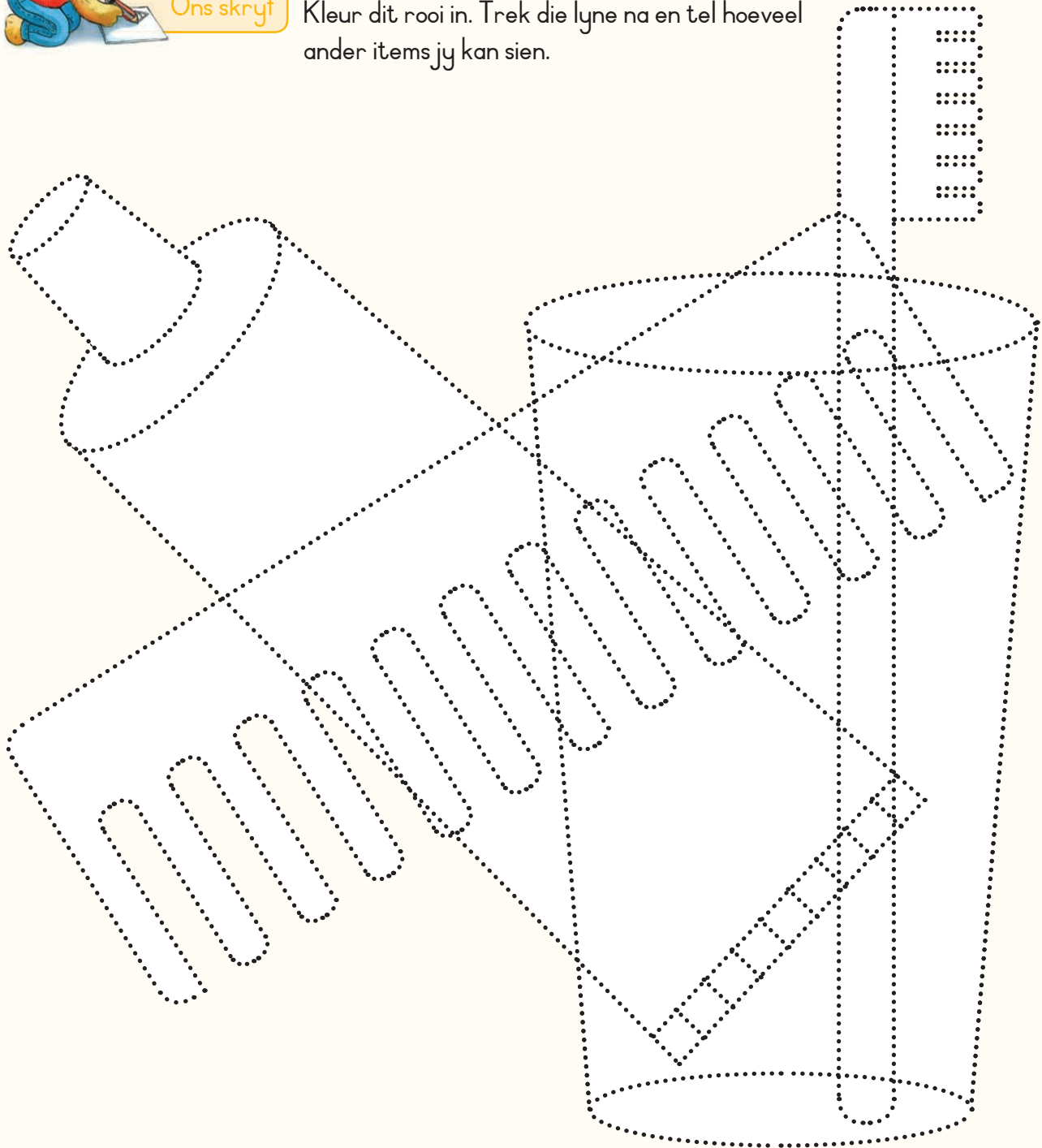



Ons skryf

Knip die stukkie van die legkaart uit en pas hulle dan weer op die regte plekke inmekaar.





4.5

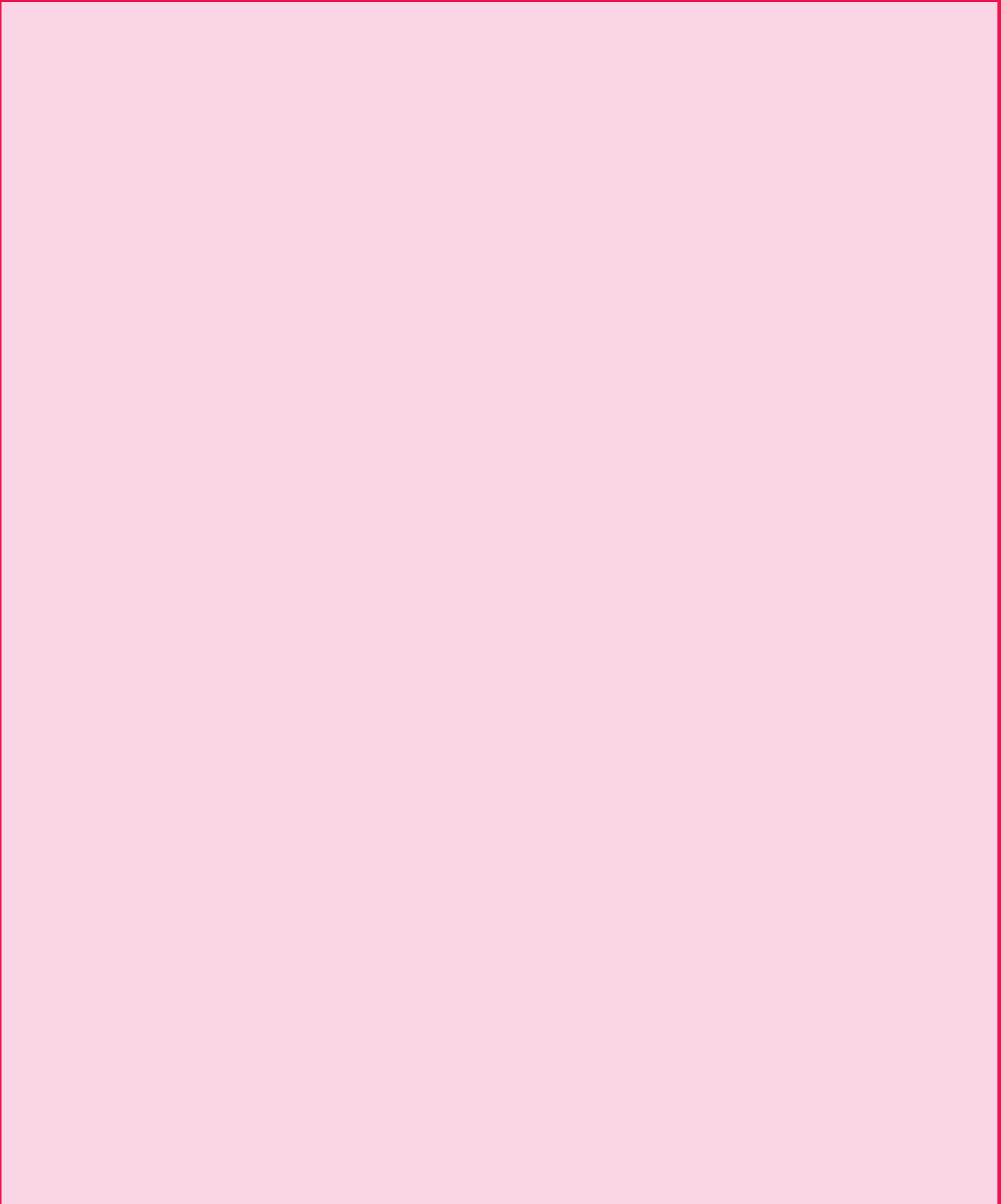



Ons doen

Knip hierdie prentjies op die stippellyne uit en plaas hulle dan in die regte volgorde.

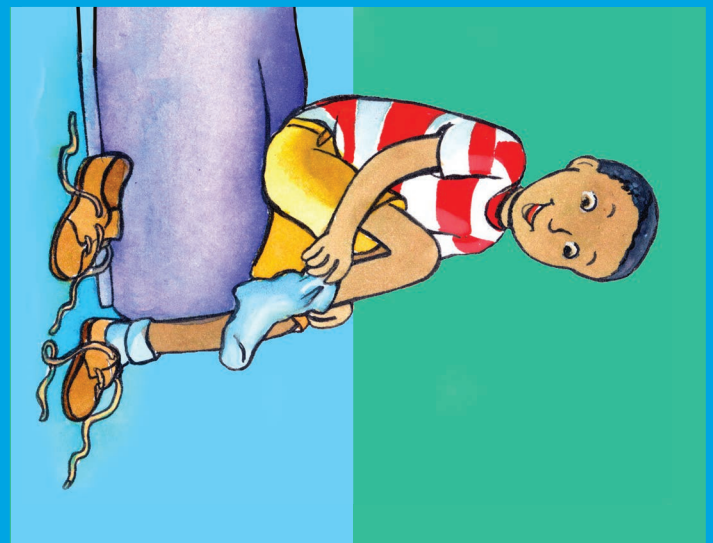

4.7



My naam is:



Ons doen

Plaas die getalle in die regte volgorde.

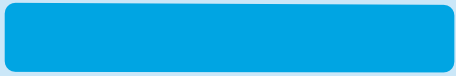

4.8



Ons tel

Plak die plakkertjies op die regte plekke.
Tel hoeveel daar van elke item is.

Plak die plakkertjies op die regte plekke.

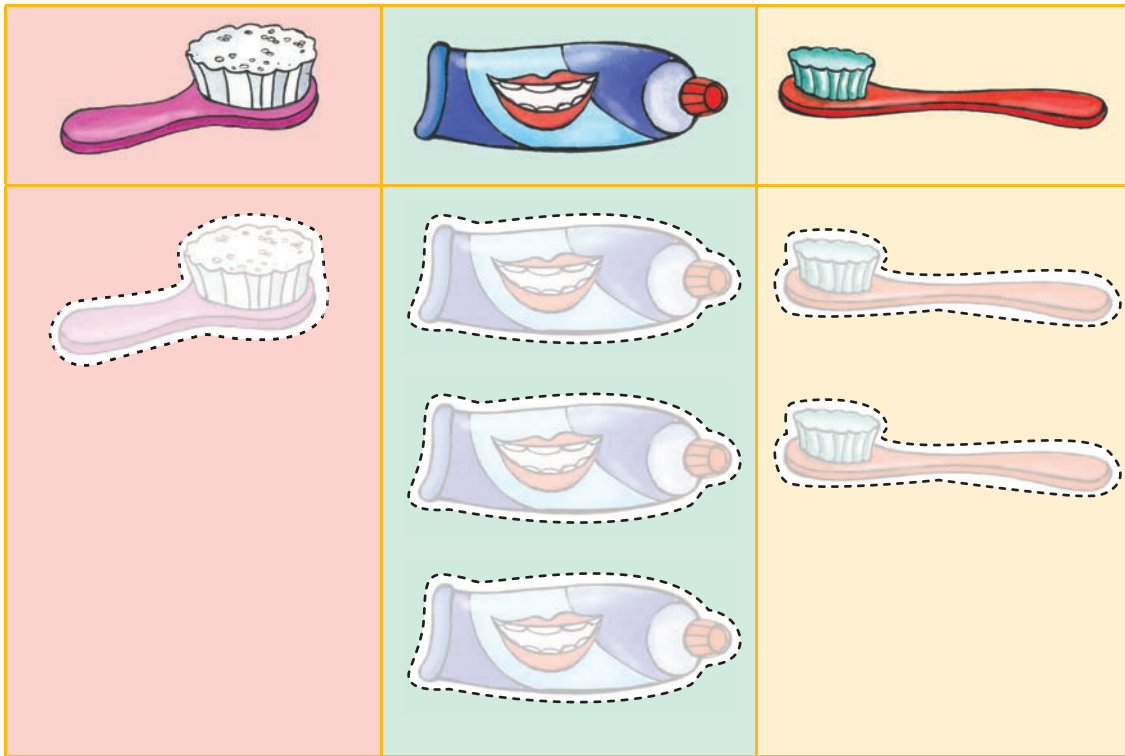
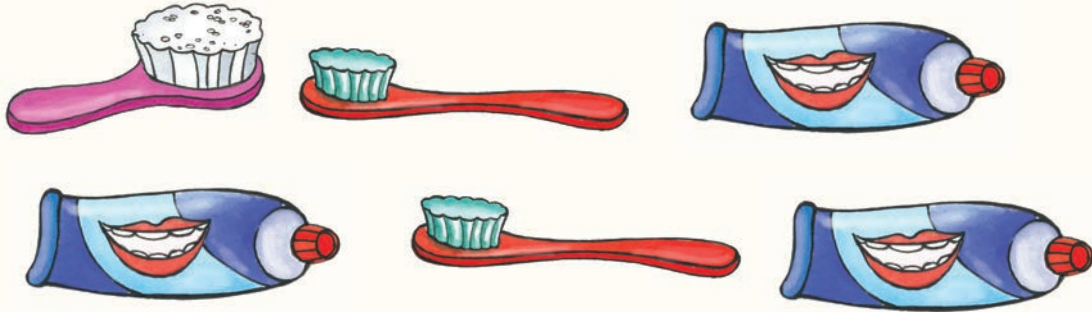

 Oefen die syfer 3.

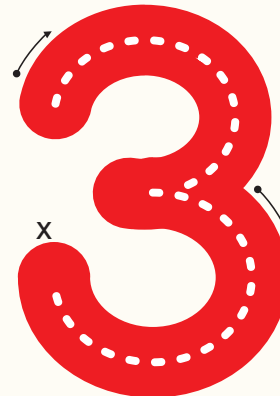
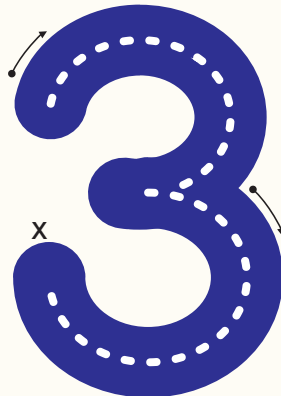
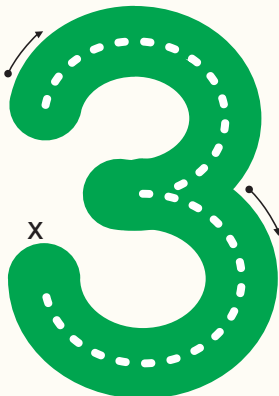

5

My maats

Kwartaal I – Week 6-10

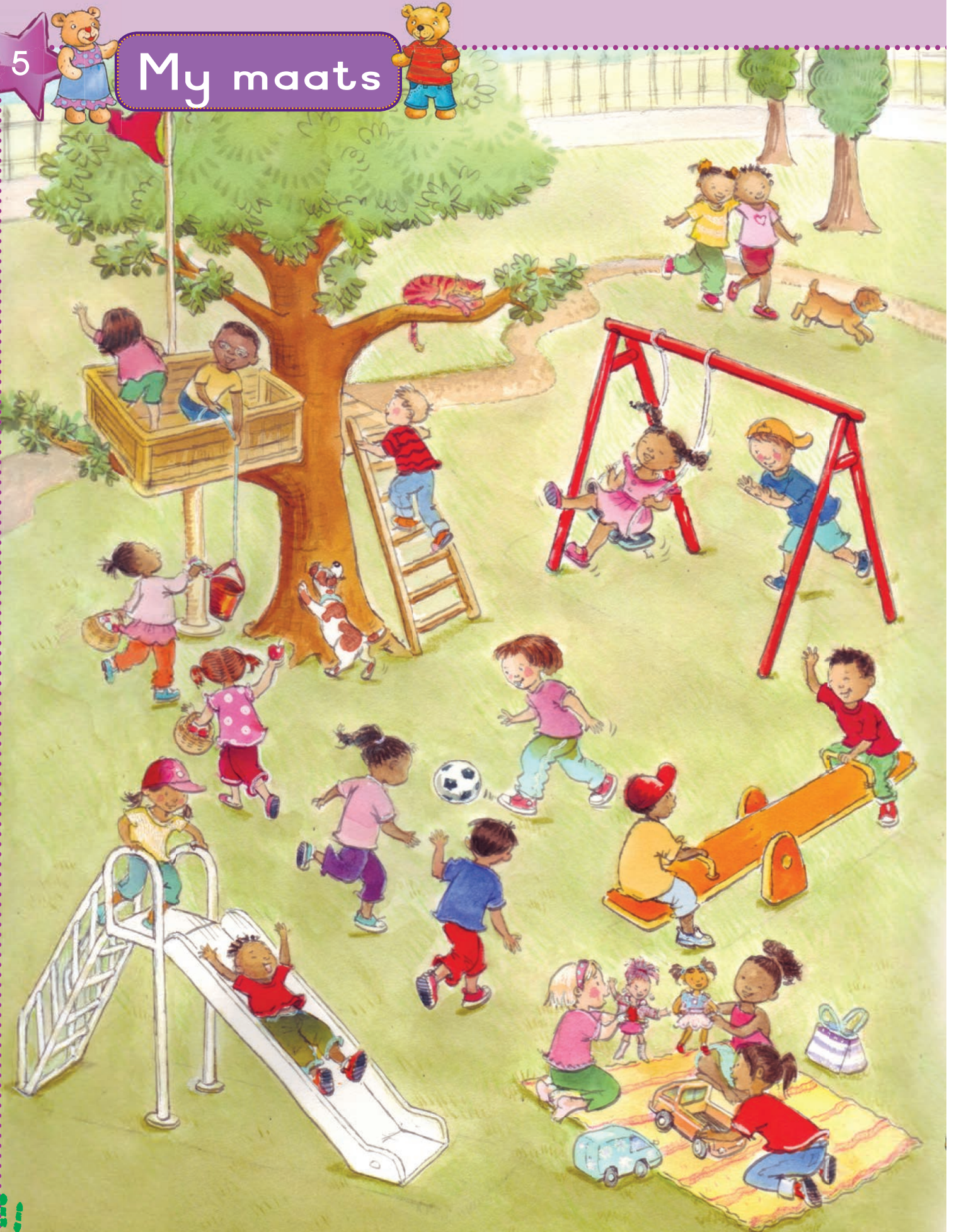

Plak die plakkertjies op die regte plekke.

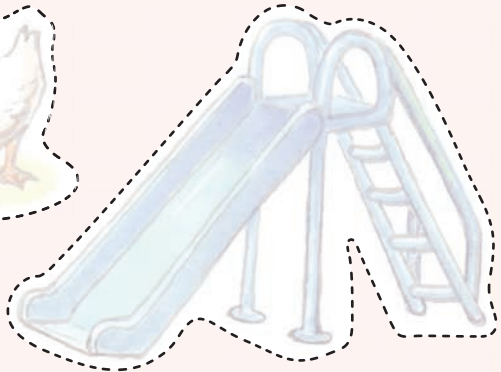
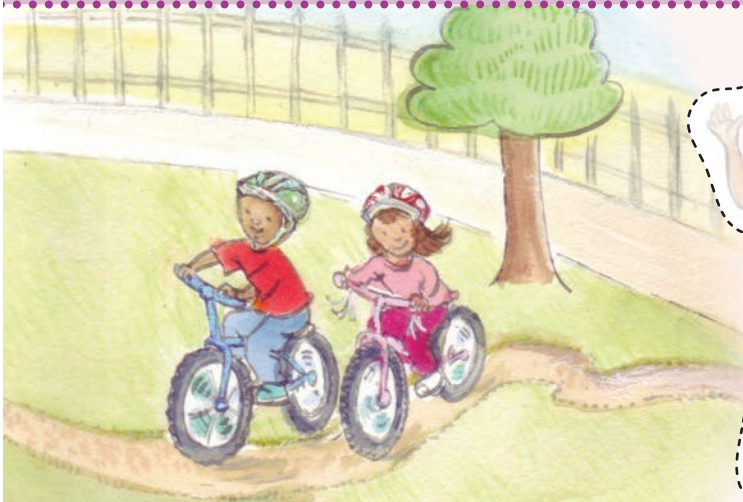

Ons praat

Het jy 'n goeie maat?
Hoe moet 'n goeie maat wees?
Wat doen julle wanneer julle speel?



My naam is:

Large empty rectangular box with a dotted border for writing.

Onderwyser: Teken

Empty box for teacher's name.

Datum

Empty box for date.



Ons skryf

Omkring die prentjie wat dieselfde as die prentjie in die eerste raampie is.

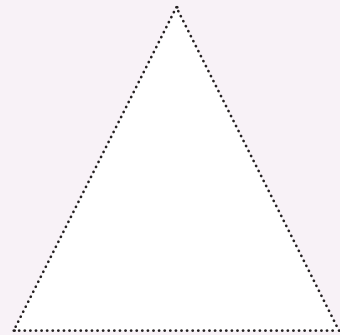
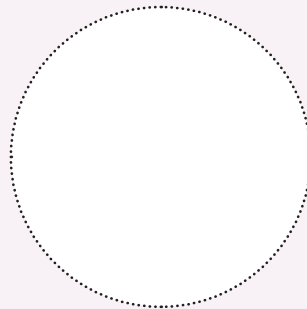
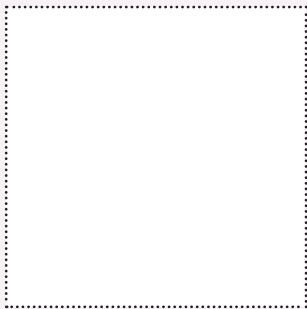
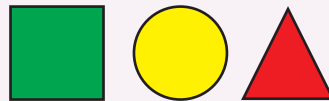

Ons skryf

Trek die vorms na en
kleur hulle soos die klein
vormpies in.



Ons doen Doen wat hierdie kinders doen.

sit



spring

spring tou



hardloop



huppel



dans



rol



loop





Ons skryf

Kleur hierdie prent in.
Gebruik dieselfde
kleure as die kleure in
die klein prentjie.





Ons doen

Trek die lyne na om hulle gunstelingklere te kry. Kleur dan die ballonne in wat daarby pas.

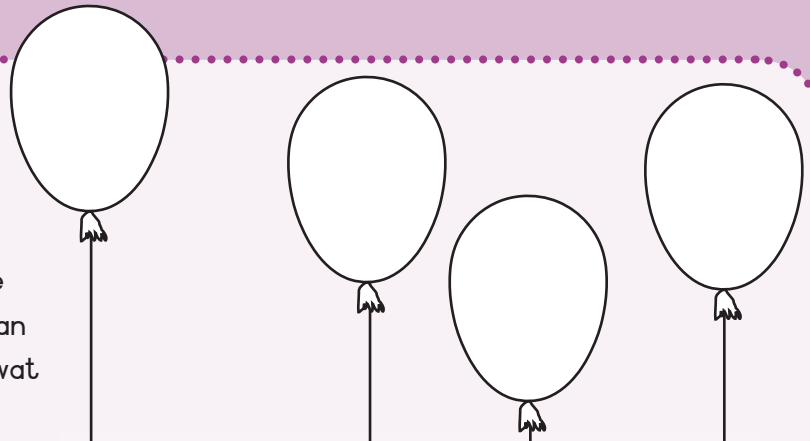

My naam is:



Ons praat

Wat doen jy graag in die somer?
Wat trek jy aan wanneer dit warm is?

Plak die
plakkertjies op die
regte plekke.
Kleur 3 appels, 3
bye, 3 tamaties en
die son in.

Dit is somer

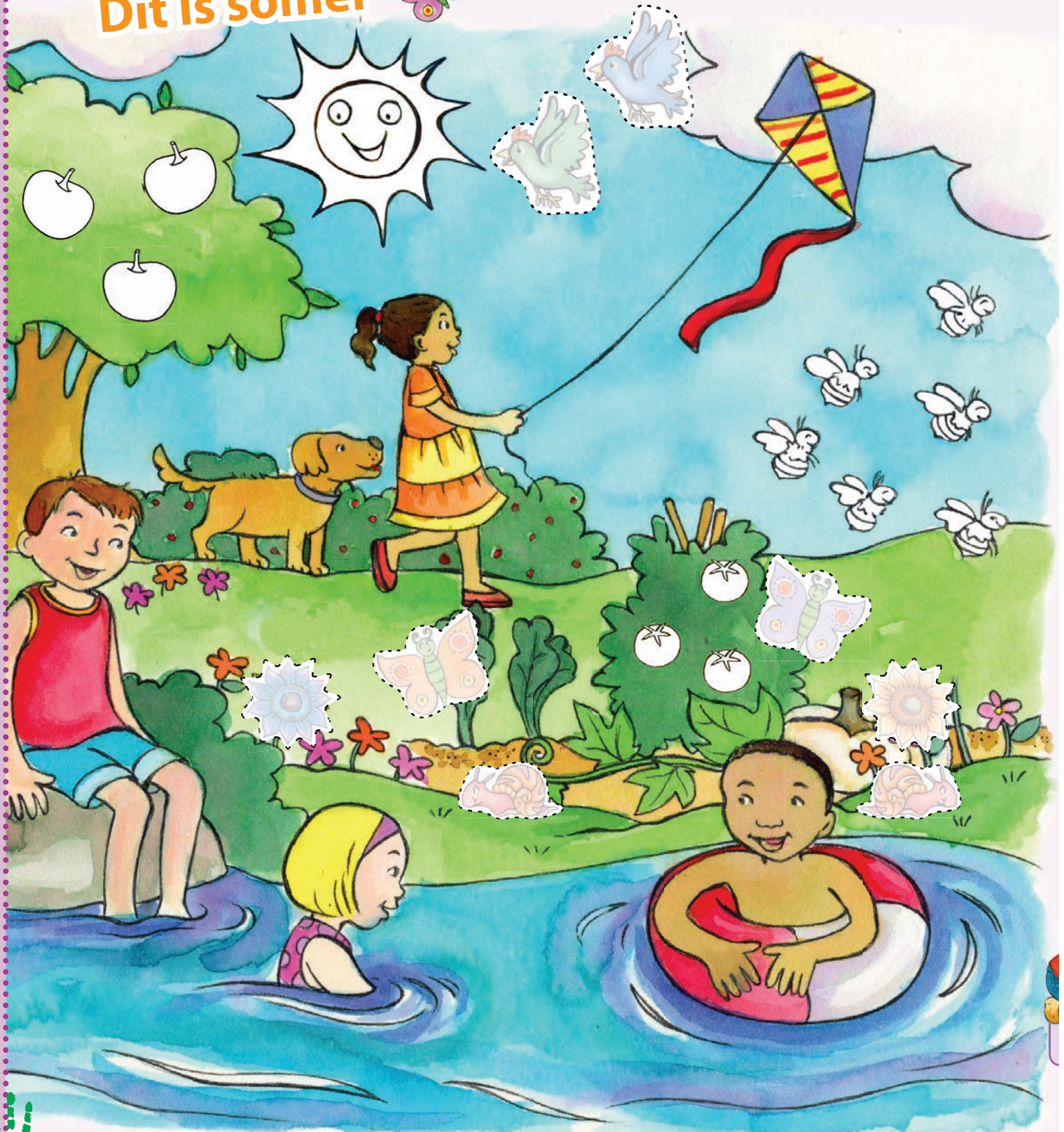

5.6



Ons skryf

Omkring die prentjies wat wys wat jy graag in die somer doen.



Skryf jou naam en klap die ritme daarvan.



My naam is:

A large empty rectangular box with a dotted border for writing a name and clapping the rhythm.

5.7



Ons doen

Kyk na die prentjies en gesels oor hoe die weer in elke prentjie verskil. Sê wat die kinders doen en watter klere hulle aanhet.

Plak die plakkertjies op die regte plekke.

Kwartaal 1 – Week 6–10

warm

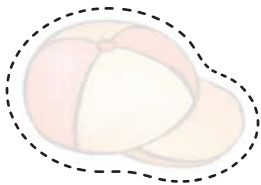
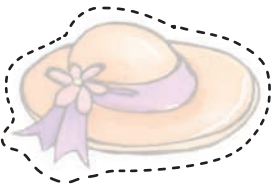



Ons doen

Omkring die kleres wat jy in warm weer dra met **rooi**, en
omkring die kleres wat jy in koue weer dra met **blou**.

koud

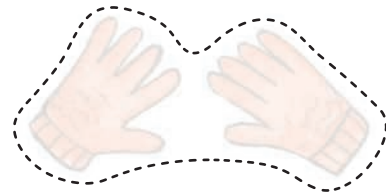
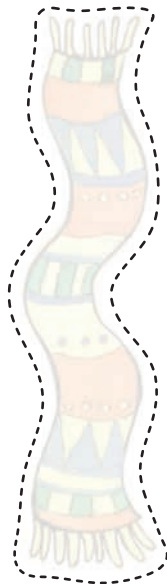
Maak boekies.
Vou op die stippellyne en
knip op die soliede lyne.



Getalles

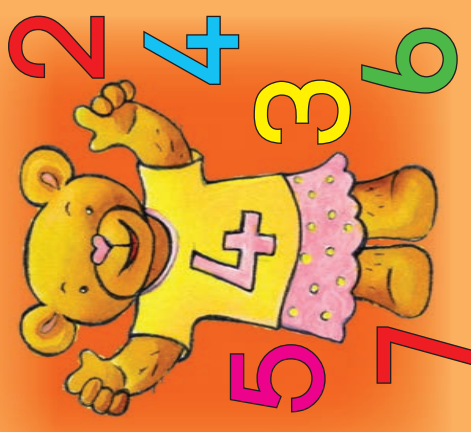

Troeteldiere



1



een

2

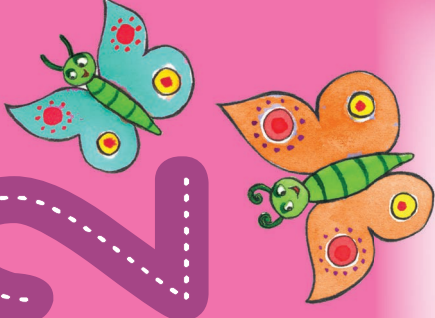

twee

3



drie



hond



kat

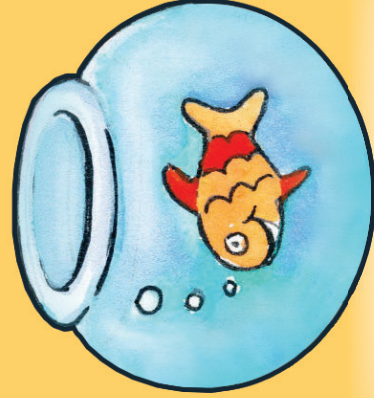

vis

akkedis



vier

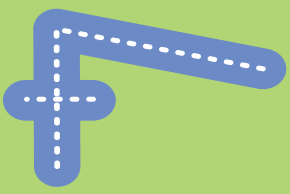
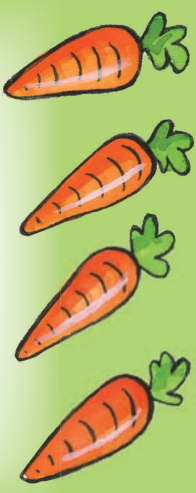

voël

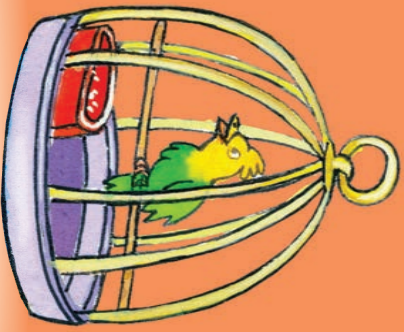

vyf

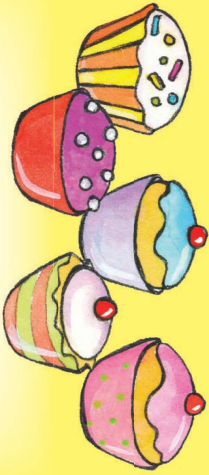

hamster

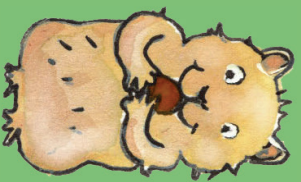

ses

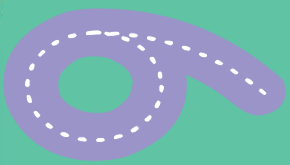

haas

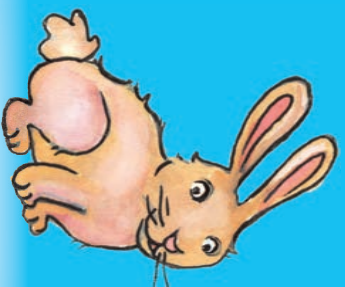

sewe

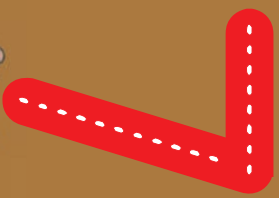



Ons doen

Knip die bladsy op die stippellyn uit en plak dit dan op die buite-omslag vas om 'n sakkie te maak. Hou jou uitknipsels daarin sodat dit nie wegraak nie.

MY UITKNIPSELS

PLAK HIER VAS

PLAK HIER VAS

PLAK HIER VAS

PLAK HIER VAS

FOLD

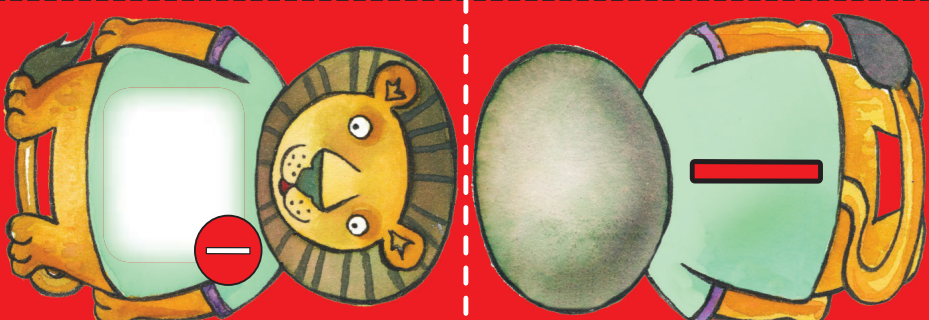
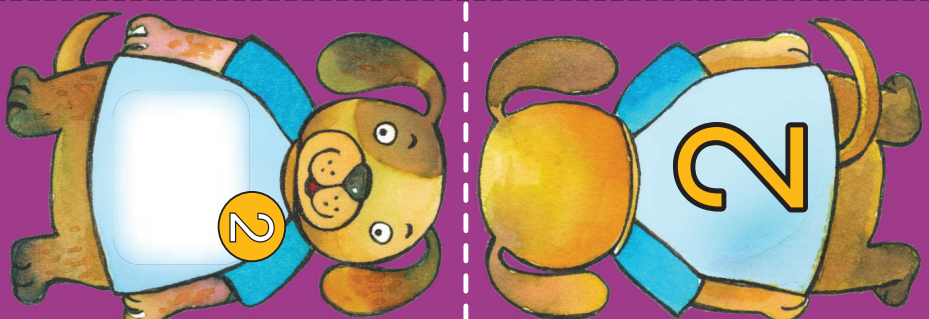
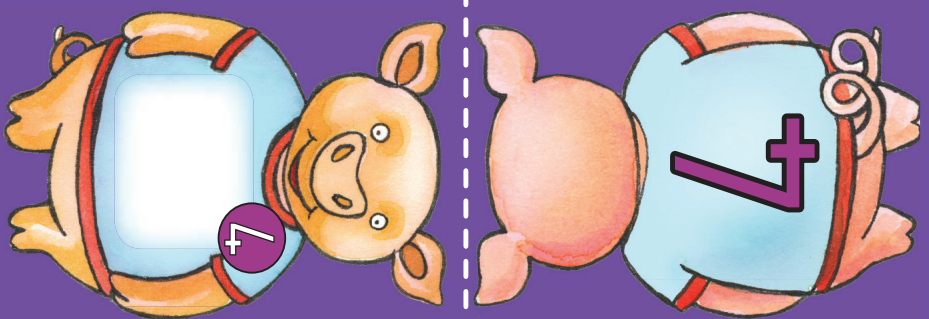
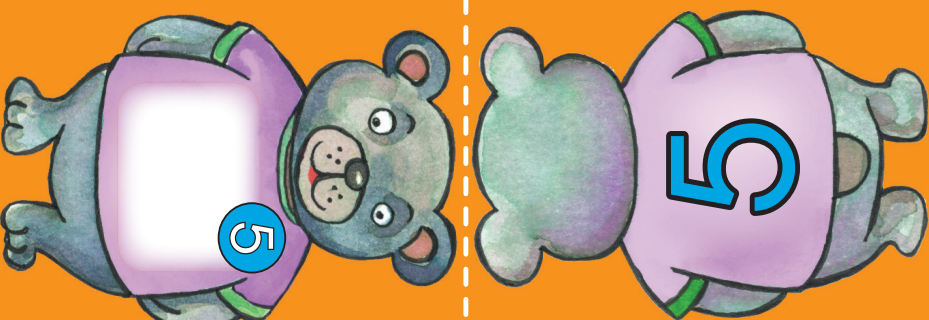

- 0
- 1
- 2
- 3
- 4
- 5
- 6
- 7
- 8
- 9
- 10
- 11
- 12
- 13
- 14
- 15
- 16
- 17
- 18
- 19
- 20
- 21
- 22
- 23
- 24
- 25
- 26
- 27
- 28
- 29

a b c d e f g h i j k l m n o p q r s t u v w x y z

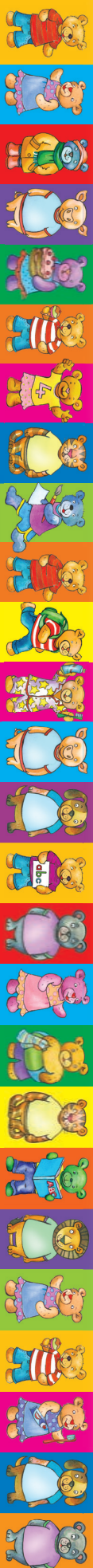

0	a	Illustration of a bear in a red shirt and blue pants
1	b	Illustration of a bear in a purple dress
2	c	Illustration of a bear in a green shirt and blue pants
3	d	Illustration of a bear in a blue shirt and blue pants
4	e	Illustration of two bears, one purple and one blue
5	f	Illustration of a bear in a striped shirt and blue pants
6	g	Illustration of a bear in a yellow shirt with the number 4 and blue pants
7	h	Illustration of a bear in a yellow shirt and blue pants
8	i	Illustration of a bear in a purple dress and blue shoes
9	j	Illustration of a bear in a red shirt and blue pants
10	k	Illustration of a bear in a striped shirt and blue pants
11	l	Illustration of two bears, one yellow and one blue
12	m	Illustration of a bear in a blue shirt and blue pants
13	n	Illustration of a bear in a blue shirt and blue pants
14	o	Illustration of a bear in a purple shirt with the number 24 and blue pants
15	p	Illustration of a bear in a purple shirt and blue pants
16	q	Illustration of a bear in a pink shirt and blue pants
17	r	Illustration of a bear in a green shirt and blue pants
18	s	Illustration of a bear in a yellow shirt and blue pants
19	t	Illustration of a bear in a blue shirt and blue pants
20	u	Illustration of a bear in a green shirt and blue pants
21	v	Illustration of a bear in a purple dress
22	w	Illustration of a bear in a striped shirt and blue pants
23	x	Illustration of a bear in a purple dress
24	y	Illustration of a bear in a blue shirt and blue pants
25	z	Illustration of a bear in a purple shirt and blue pants

GLUE HERE

GLUE HERE

GLUE HERE

GLUE HERE

GLUE HERE

GLUE HERE

GLUE HERE

GLUE HERE

GLUE HERE

GLUE HERE



1

1

2

2

3

3

4

4

5

5





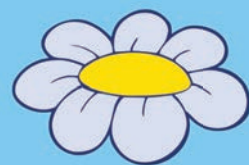
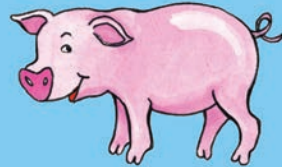
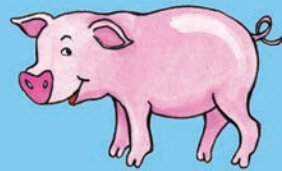

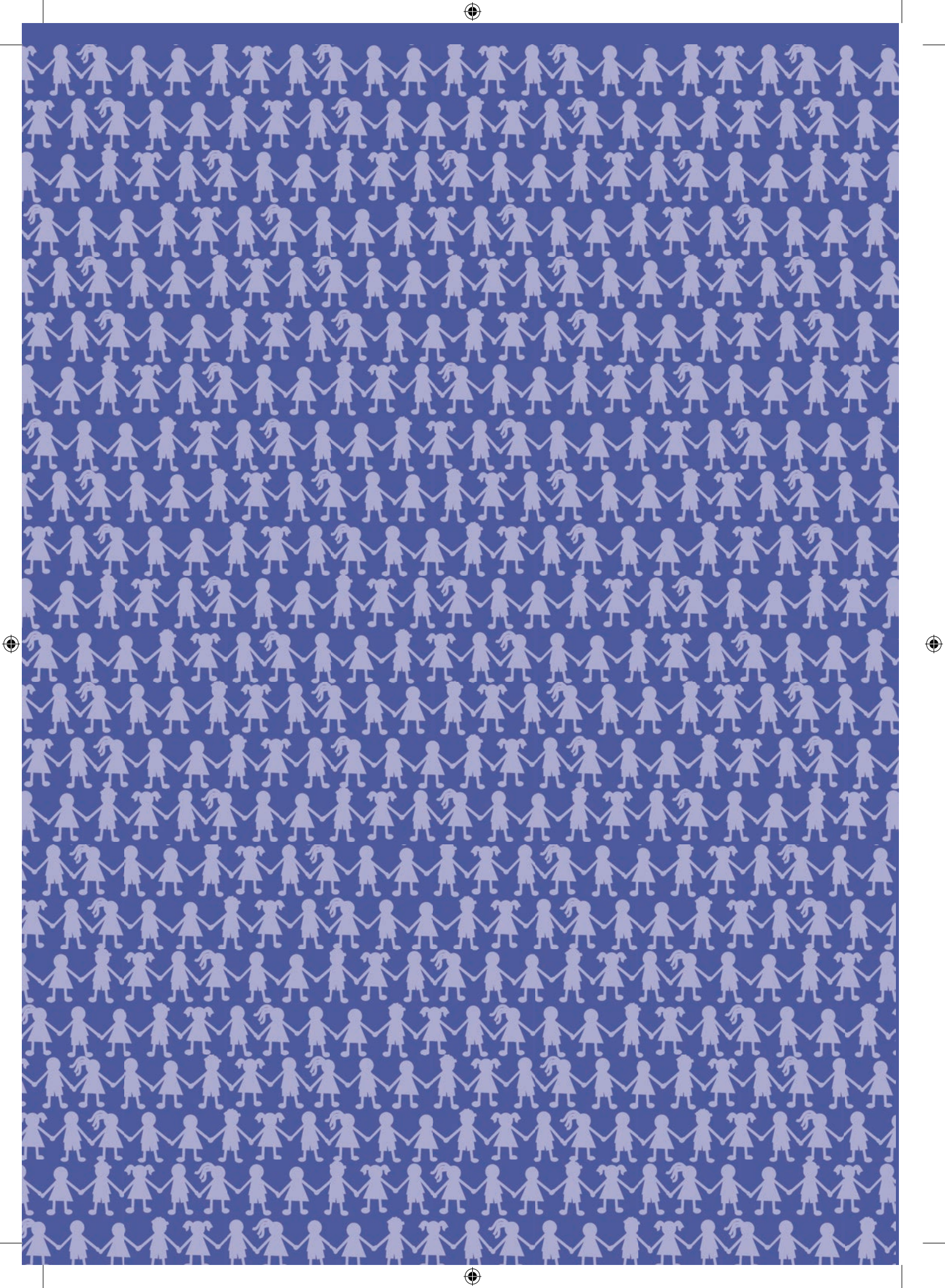

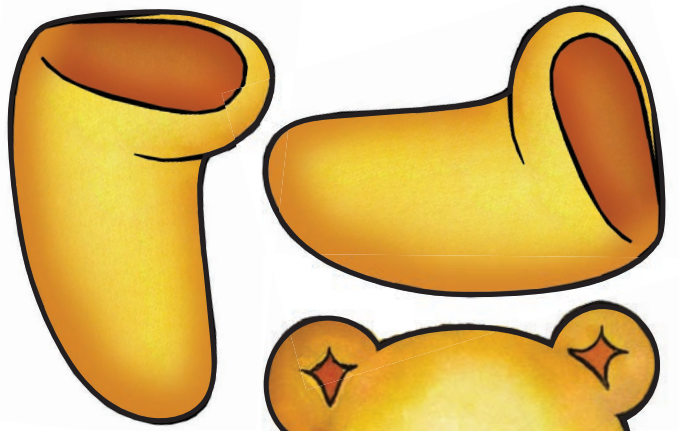
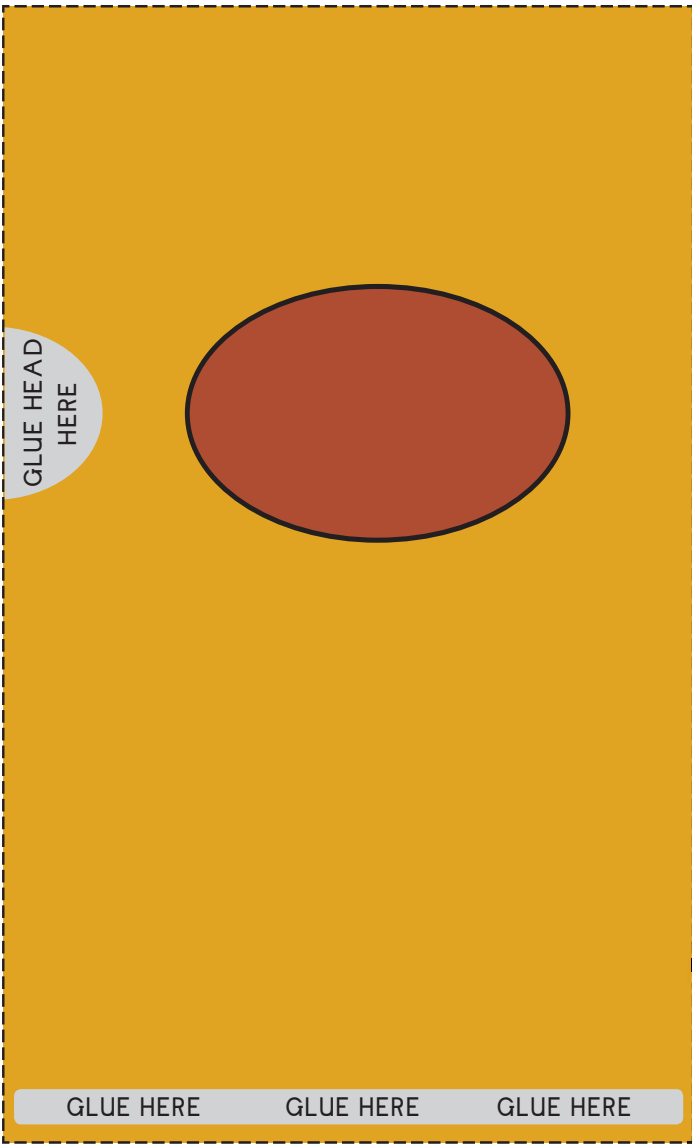

TEDDY BEAR

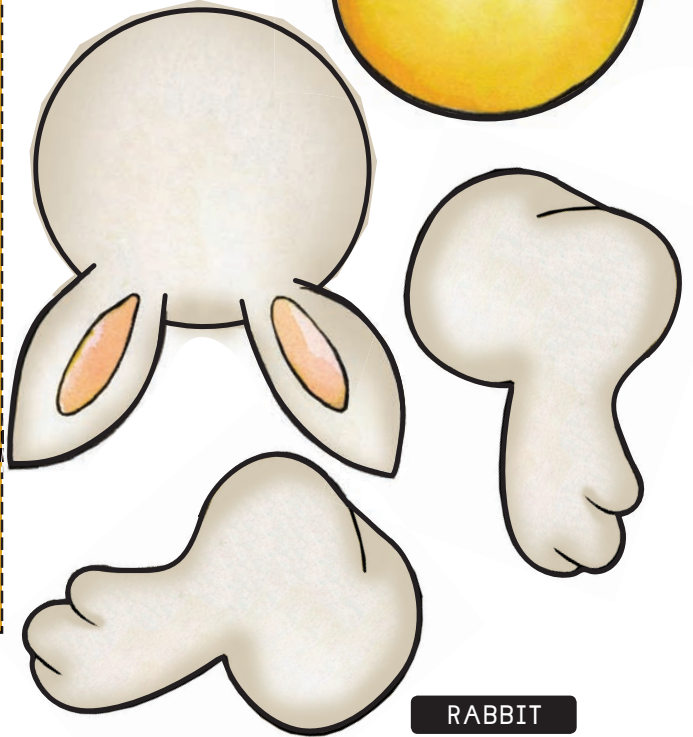

RABBIT

