

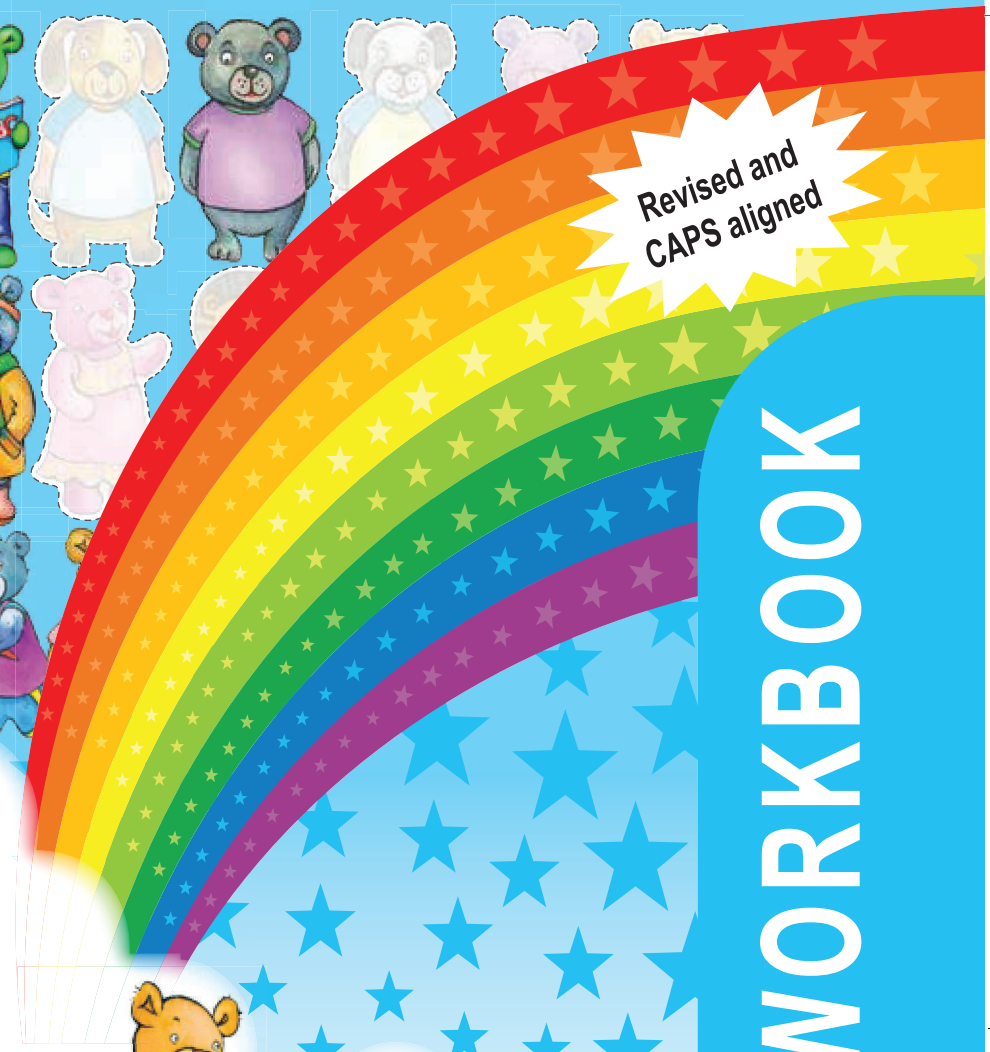

Revised and  
CAPS aligned



# Grade R WORKBOOK 1



Name:  Class:



basic education  
Department:  
Basic Education  
REPUBLIC OF SOUTH AFRICA

ENGLISH WORKBOOK

Book 1  
Term 1

Rainbow  
WORKBOOKS

ENGLISH  
GRADE R – BOOK 1  
TERM 1  
ISBN 978-1-4315-0689-7  
THIS BOOK MAY NOT BE SOLD.  
11th Edition





Mrs Angie Motshekga,  
Minister of Basic  
Education



Dr Reginah Mhaule,  
Deputy Minister  
of Basic Education

These Reception year (Grade R) Rainbow Workbooks form part of the Department of Basic Education's strategy to boost South African children's school performance. Research shows that for every year that children are exposed to stimulating activities before Grade 1, they perform better academically in later years – throughout their primary and secondary schooling. Hence this strong focus on learning in Grade R.

The Foundation Phase curriculum requires that Grade R learners are given the opportunity to develop their pre-reading, pre-writing and pre-mathematics skills and outlines the skills they will need to get a solid educational foundation so that they find it easier to learn in Grade 1 and beyond.

The Grade R workbooks therefore aim to assist children in developing these skills and the key initial concepts they need to lay a solid foundation for learning. They are packed with opportunities for children to develop and practise the skills that will prepare them for formal schooling.

Before children formally learn to read they need to find out how to hold a book and turn its pages, and to understand how books work. They need to understand the relationship between the words and pictures in a book and to realise that words on a page are made up of sounds and have meaning. Similarly, before children learn to write, they need to develop their fine motor coordination, to practise the formation of shapes and then to move on to forming letters. These are precisely the skills that these workbooks aim to develop.

We know that all children do not learn at the same pace the Grade R workbooks make it possible for teachers to work at the learner's individual pace and, where necessary, to go backwards and forwards in the book, in line with each child's unique development. The activities will also assist teachers in identifying barriers that children may have in learning so that these can be addressed before the child starts formal schooling.

The workbooks integrate the teaching of literacy, numeracy and life skills across 20 themes using fun and engaging ways to capture young learners' interest and attention. We hope that your learners will enjoy working through the workbook activities as they grow and learn, and that you, as their teacher, will share in their pleasure.



Alphabet

Aa



Bb 	Cc 	Dd 	Ee 	Ff 
Gg 	Hh 	Ii 	Jj 	Kk 
Ll 	Mm 	Nn 	Oo 	Pp 
Qq 	Rr 	Ss 	Tt 	Uu 
Vv 	Ww 	Xx 	Yy 	Zz 

# Grade R

## INTEGRATED

- Literacy
- Numeracy
- Life Skills

# W o r k b o o k

in ENGLISH

1	About Me .....	2
2	In the classroom .....	12
3	My body .....	22
4	Healthy living.....	32
5	Friends .....	42



The instructions for the cut-outs are at the back of the book.



### To the Educator:

Learners need to practise their work before they attempt to complete the activities in their workbooks. For example:

- When learners are required to circle the correct answer, let them first place a marker on the correct answer. They should then check with the teacher that it is correct before they write in their books.
- When the activity requires learners to trace something, let them do it with their fingers first before they do it in writing.

**Please note:** Learners are all at different developmental stages.

If you see that some learners still need attention to develop their fine motor skills, let them practice their work in their lined exercise books until they are confident enough to write in their workbooks.



# ENGLISH

## Book



## Term 1



# About Me



I am in Grade R

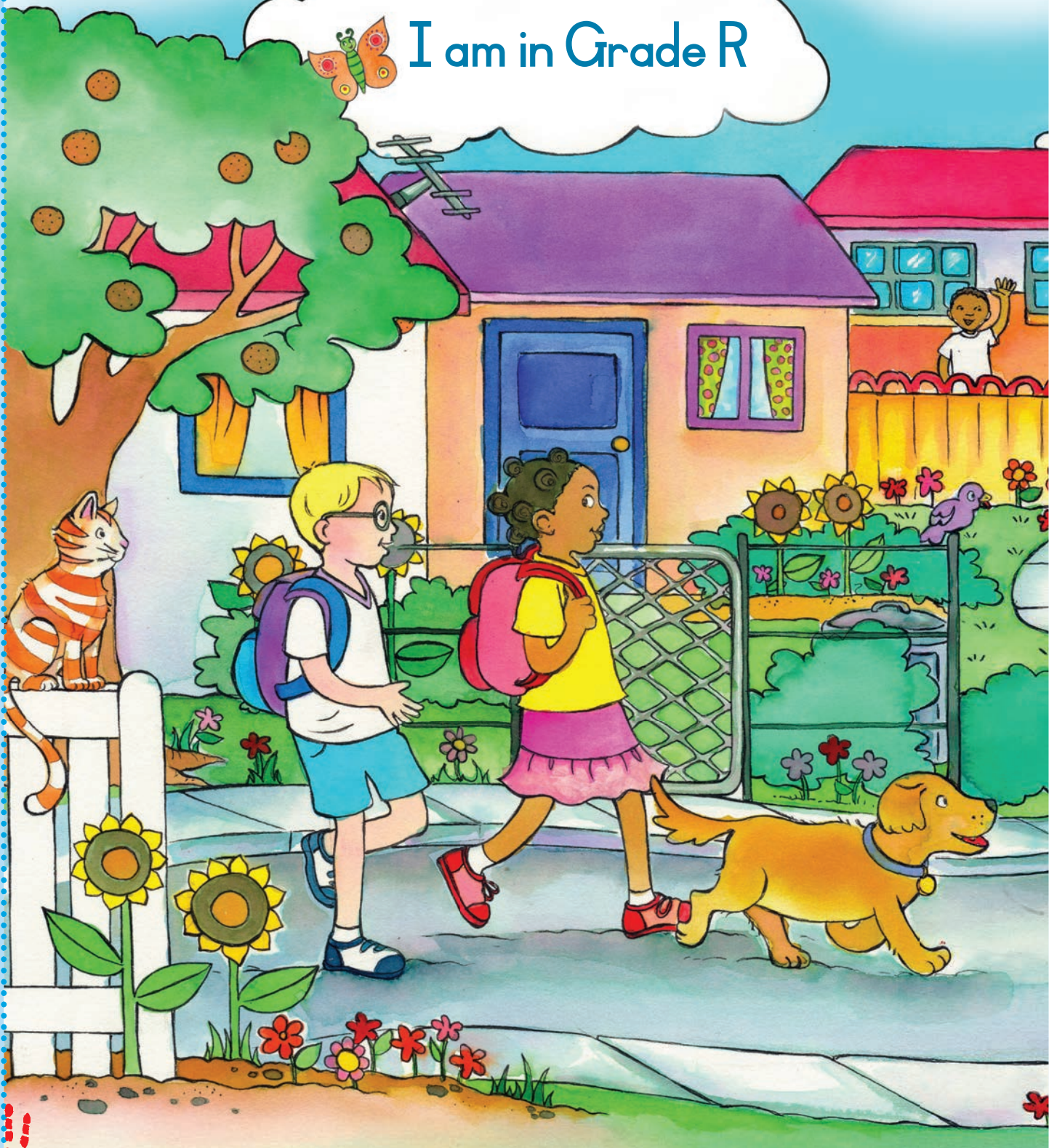



My name is:

Blank box for writing a name.

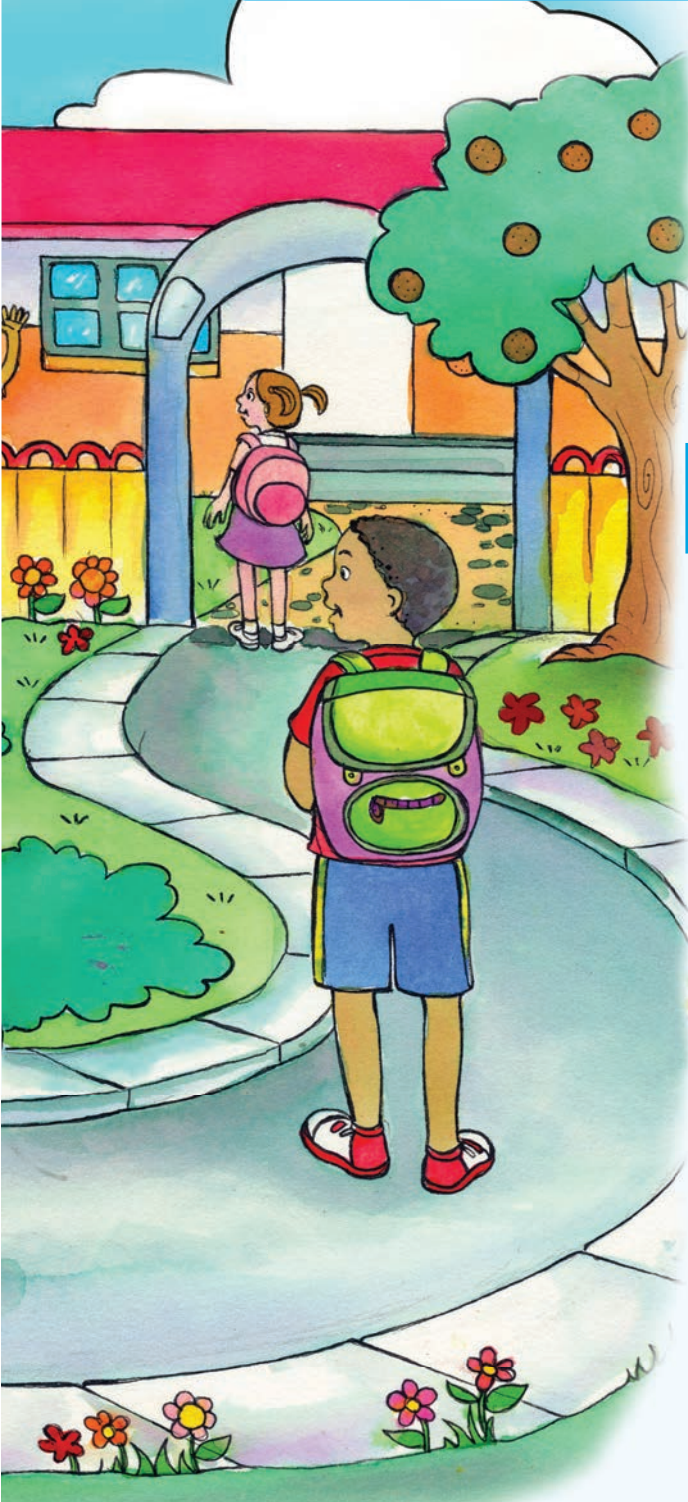

I am a

boy

boy

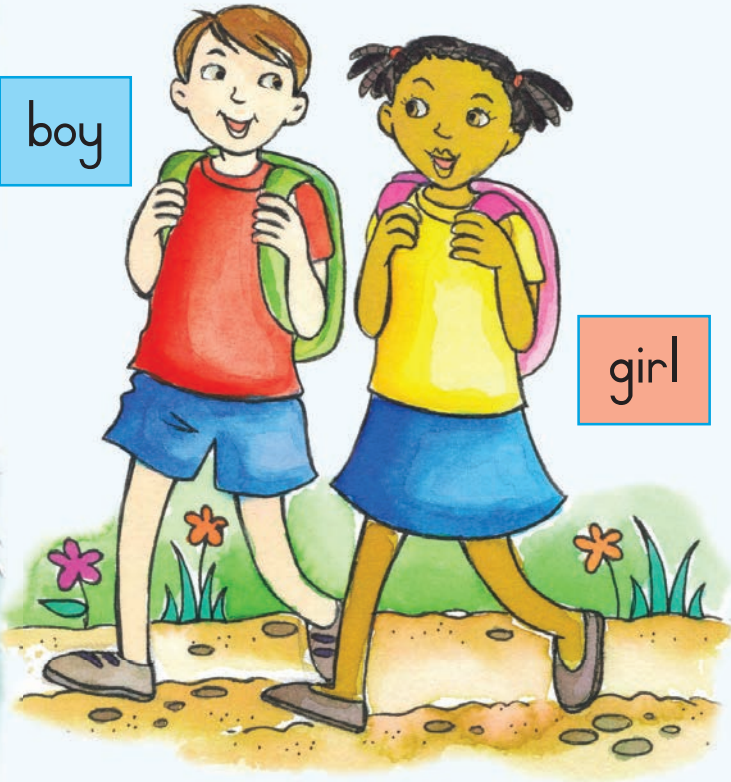

girl

I am a

girl

TEACHER: Sign

Blank box for teacher's signature.

Date

Blank box for the date.





Let's do

Draw a picture of yourself.

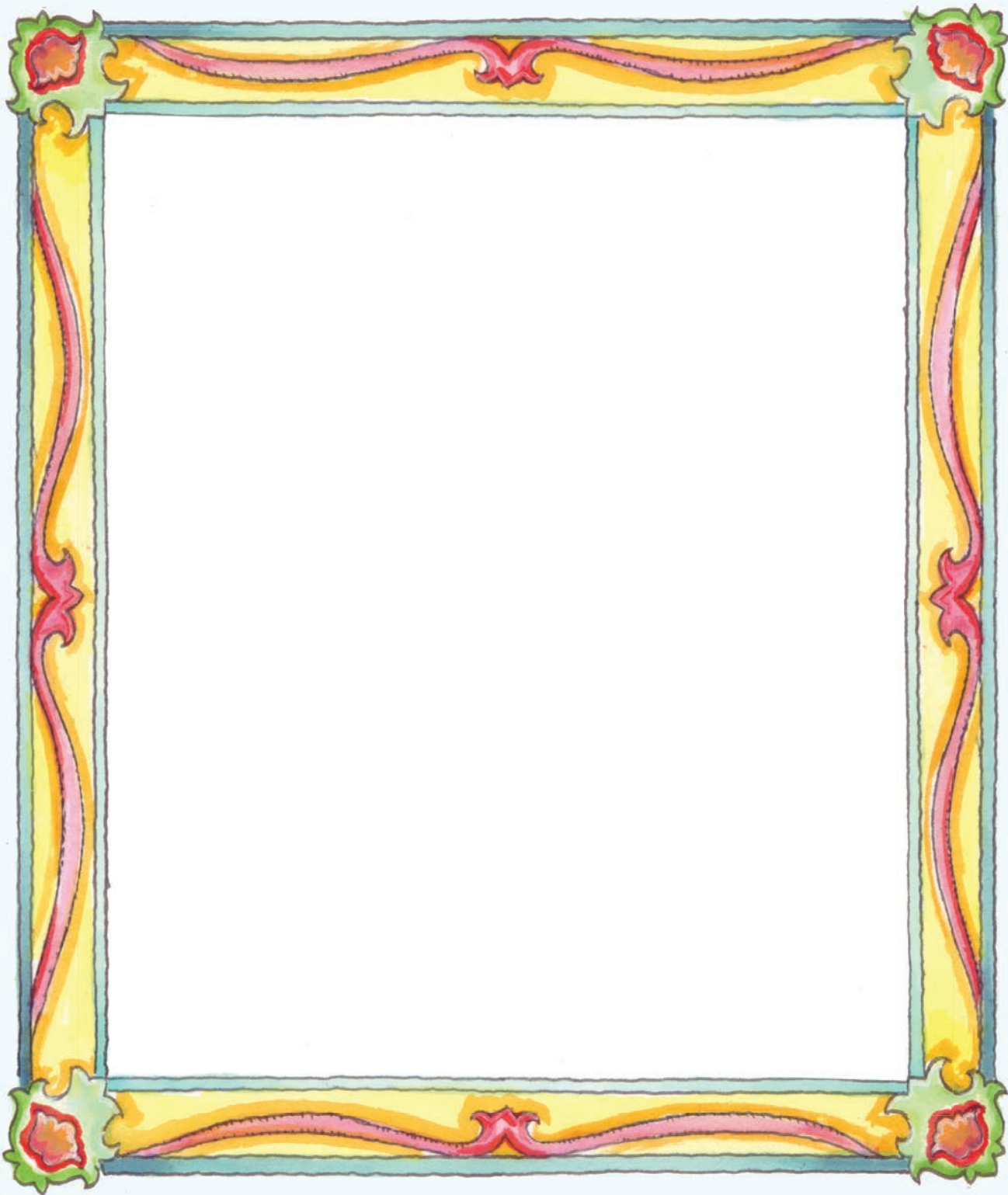

1.2



My name is:

A large empty rectangular box with a dotted border, intended for writing a name.



Let's do

Colour the correct number of candles to show how old you are.



I am

5

6

7

years old.

TEACHER: Sign

\_\_\_\_\_

Date

\_\_\_\_\_





Let's write

Paste the stickers in the correct places. Then, trace the line with your finger and then with a crayon.

Paste the stickers in the correct spaces.



Help the boy to find his bike.

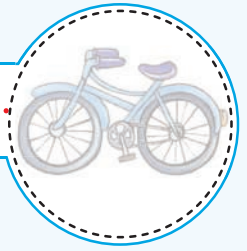
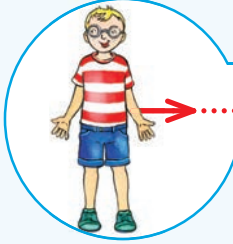

Help the girl to kick the ball.

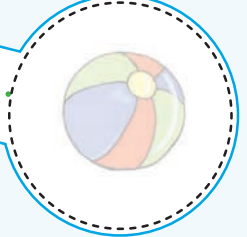
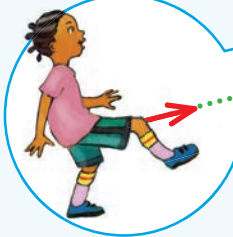

Trace the string to the kite.

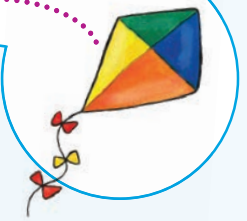
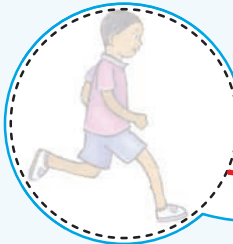

Drive the car to school and then back home.

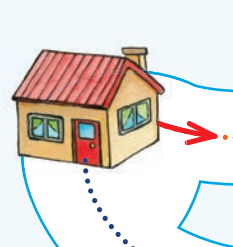

For extra practice, let learners trace over their lines a few times using different colours.





# How much I weigh

Let's write



[Blank box for writing weight]

kg

# How tall I am

[Blank box for writing height]

cm



# My eye colour

<input type="checkbox"/>		<input type="checkbox"/>	
	<input type="checkbox"/>		<input type="checkbox"/>

# My hair colour

	<input type="checkbox"/>	<input type="checkbox"/>	<input type="checkbox"/>	<input type="checkbox"/>	<input type="checkbox"/>	



Let's do

Paste in a star sticker to show what you like to do.

Paste the  
stickers  
in the correct  
spaces.

I like to:

dance



read a story



play with my friends



play with a ball



build with blocks



sing





Let's write

Draw a picture of what you like to do.



My name is:

TEACHER: Sign

Date











My name is:

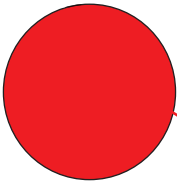



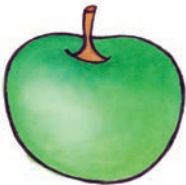



Let's write

Match the pictures.

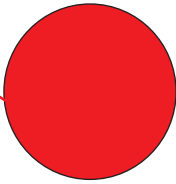



Let's count

Circle the blocks that have 1 item.  
Clap your hands once for each item you see.

Practise the numbers.



2

# In the classroom

Paste the stickers in the correct spaces.



Let's write

Look at the picture and talk about what the children are doing?  
What do you like to do?

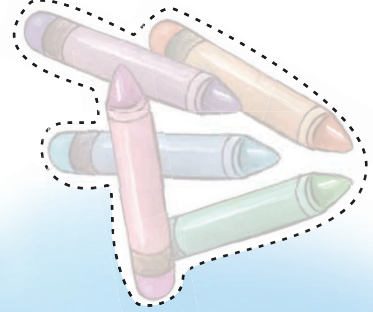



My name is:

Large empty rectangular box with a dotted border for writing a name.



TEACHER: Sign

Blank rectangular box for teacher signature.

Date

Blank rectangular box for date.



Let's write

Draw strings for the balloons.  
Which balloon has the shortest string?  
Which balloon has the longest string?

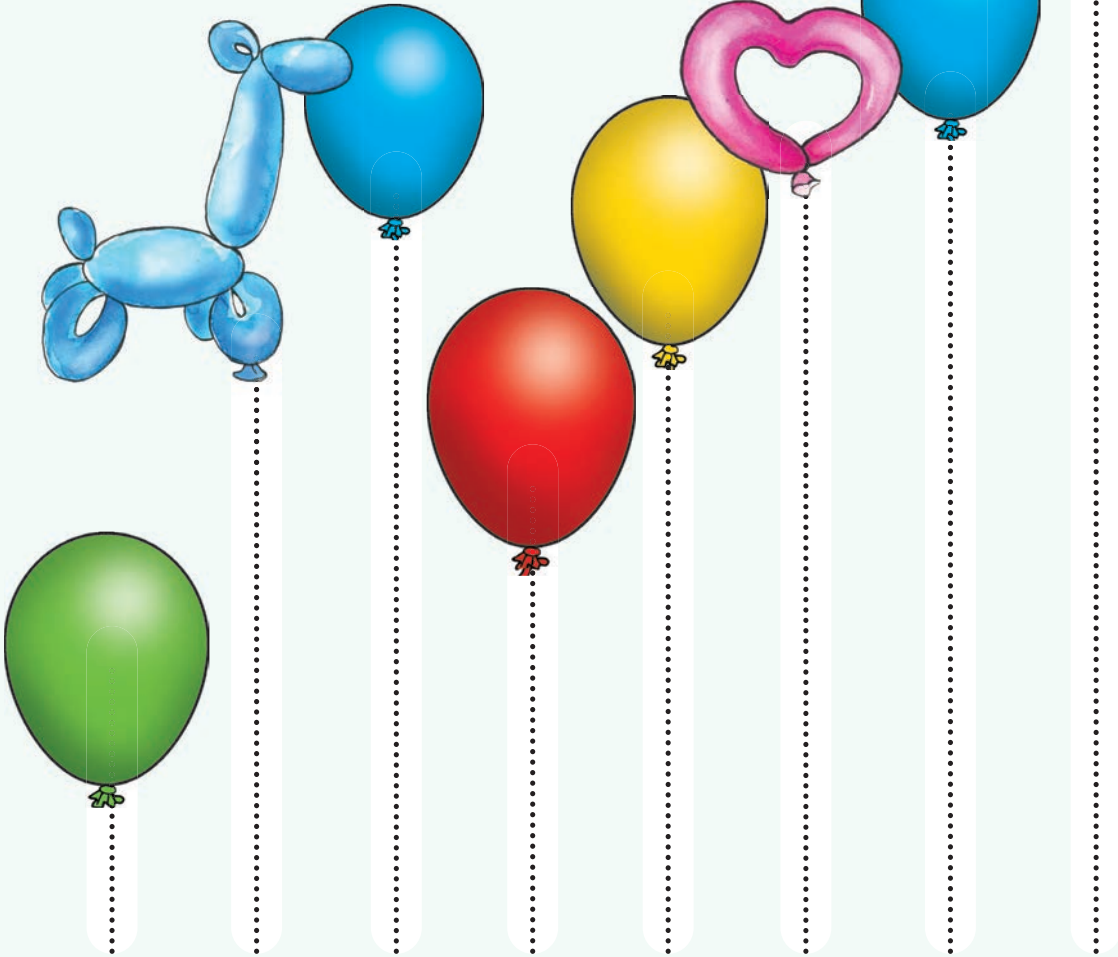

Colour the balloons in red, yellow, green and blue.

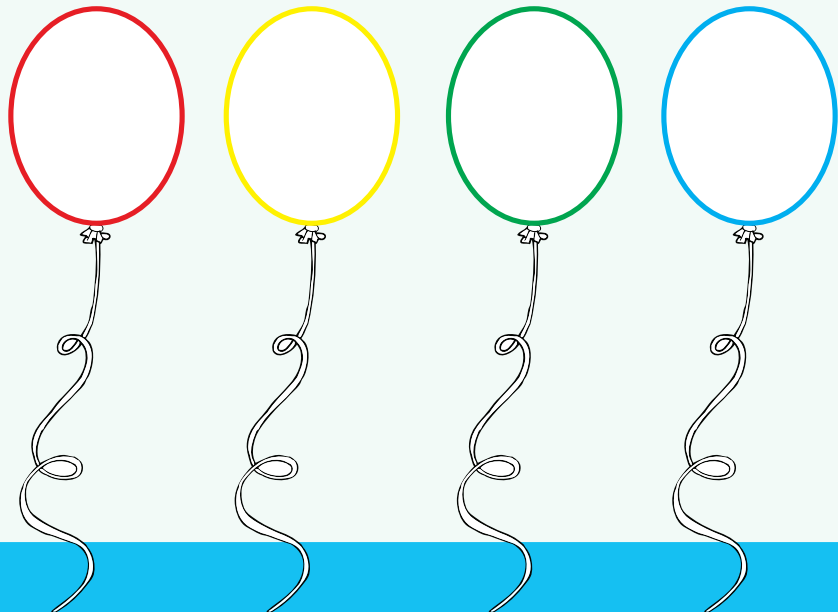





Let's write

Find the faces that show the same emotion as the emotion in the first picture.



Let's do

Where is this boy looking? Without moving your head, move your eyes so that you look in the same direction that the boy is looking.





Let's count

Circle the blocks that have 2 items in them.  
Clap twice each time you see 2 items.

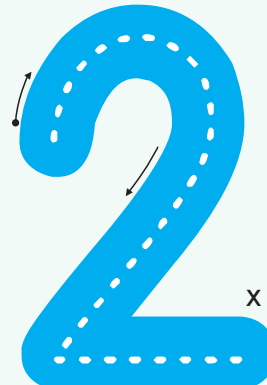
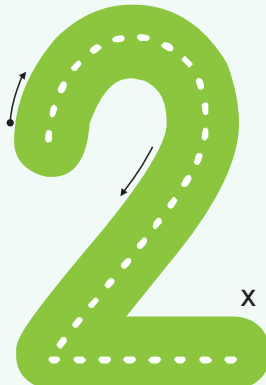
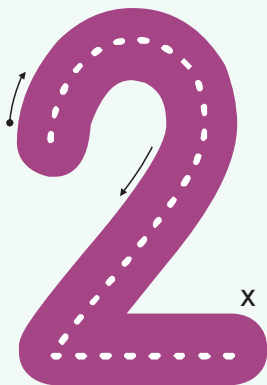

Practise the number 2.





Let's write

Colour 2 items in each row.

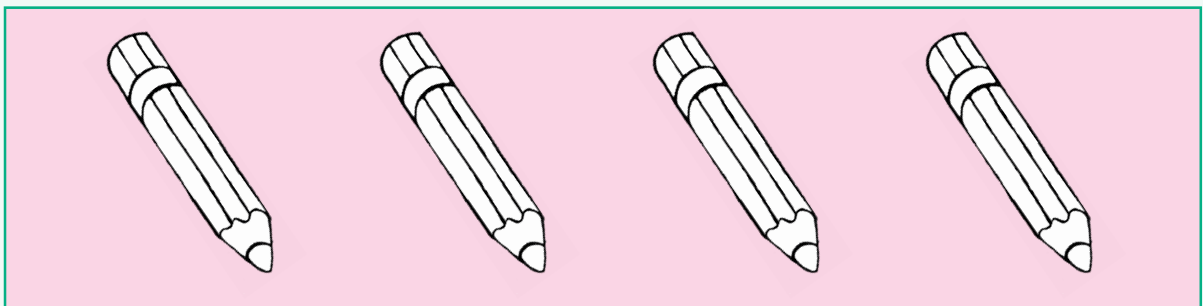
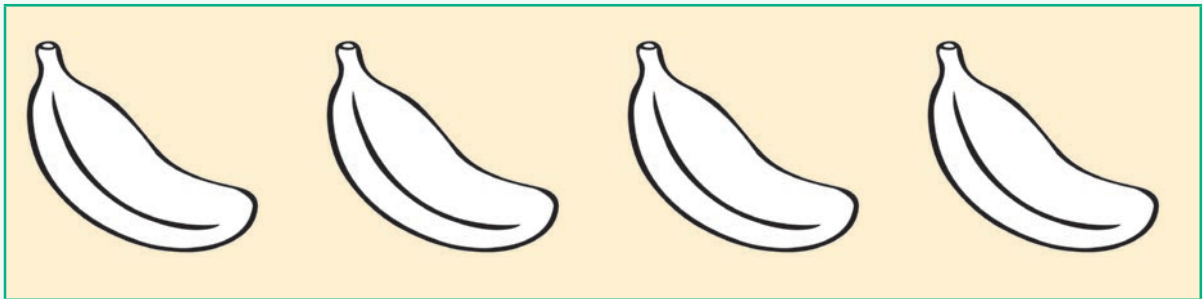
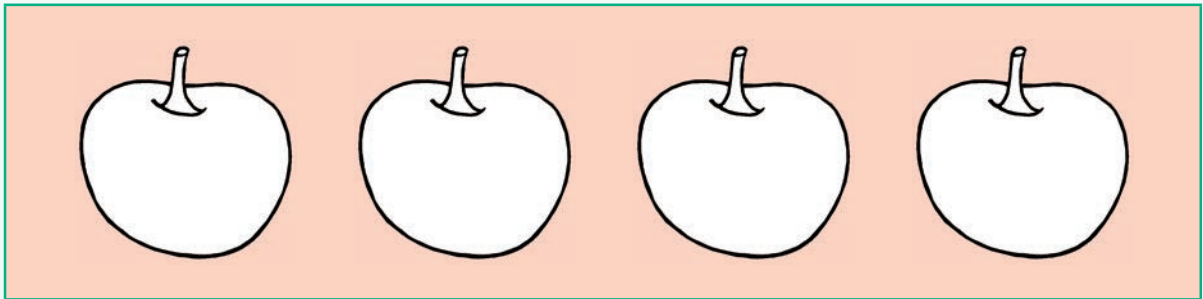
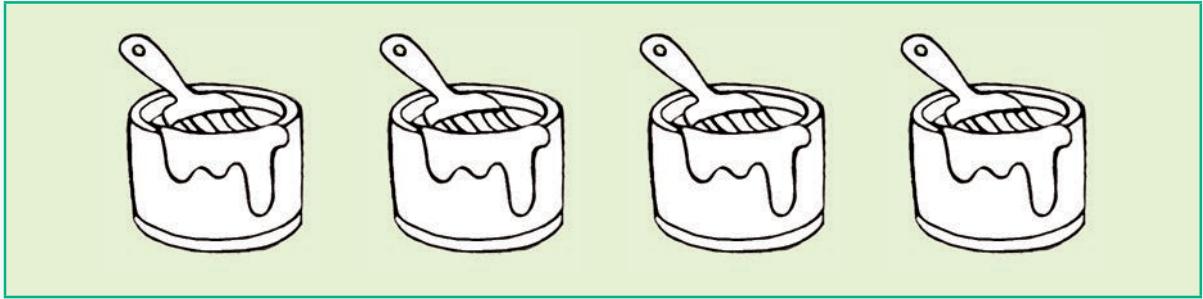

My name is:

A large rectangular box with a dotted border, intended for writing a name.



Let's do

What do you carry in your school bag?  
Paste in the stickers to pack the bag.



eraser



sharpener



crayons



scissors



lunch box

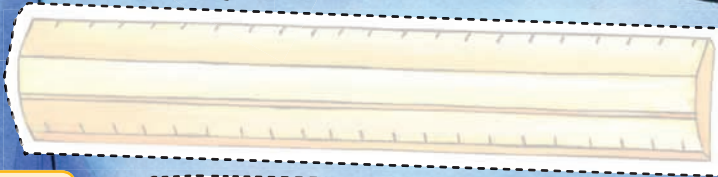

ruler



pencil box

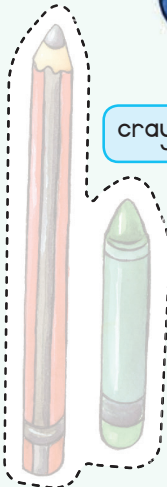

crayon

pencil



Let's write

Write your name  
on the school bag.

Name: \_\_\_\_\_





Let's write

Paste the stickers in the correct places. Then, trace the line with your finger and then with a crayon.

Paste the stickers in the correct spaces.

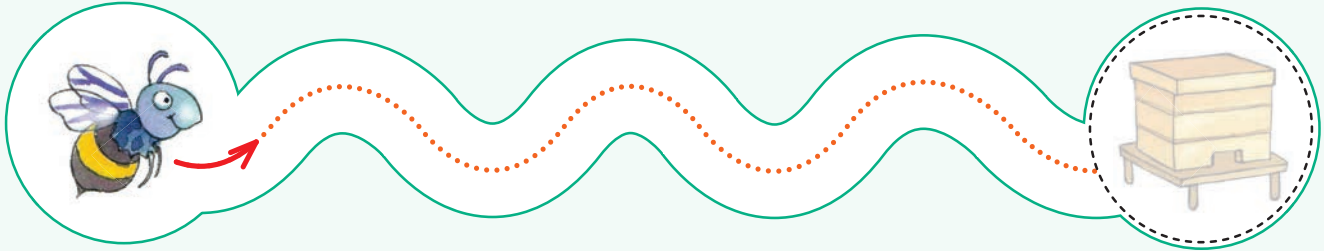
 Help the bee find its hive.



 Help the frog find the pond.

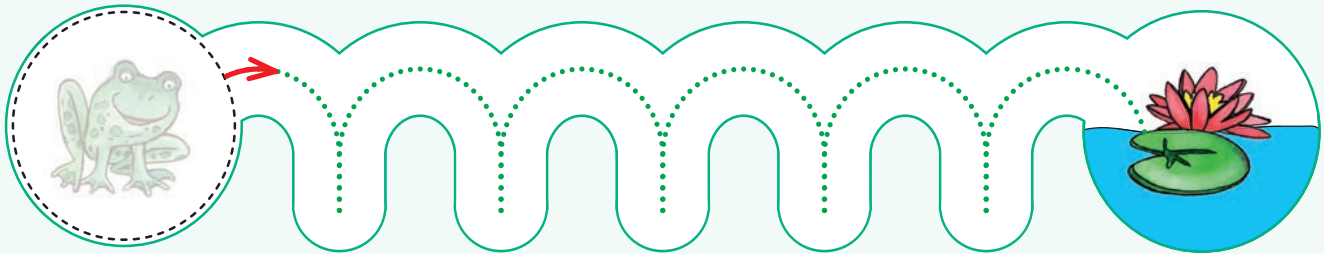

 Help the bird find its nest.

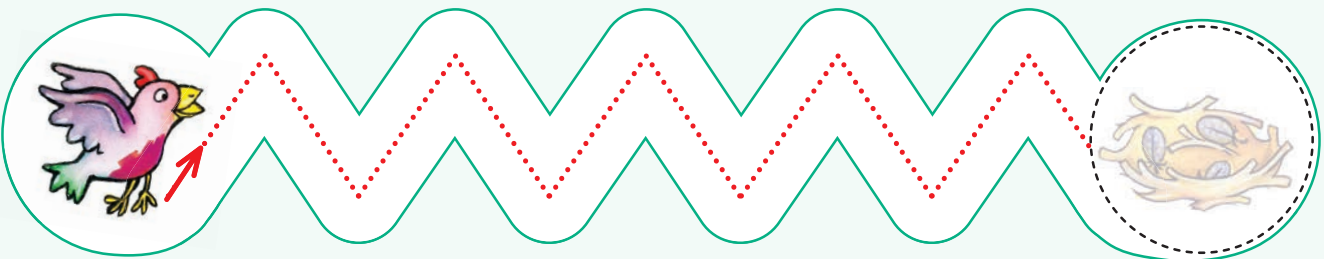

 Help the boat to get to the island.

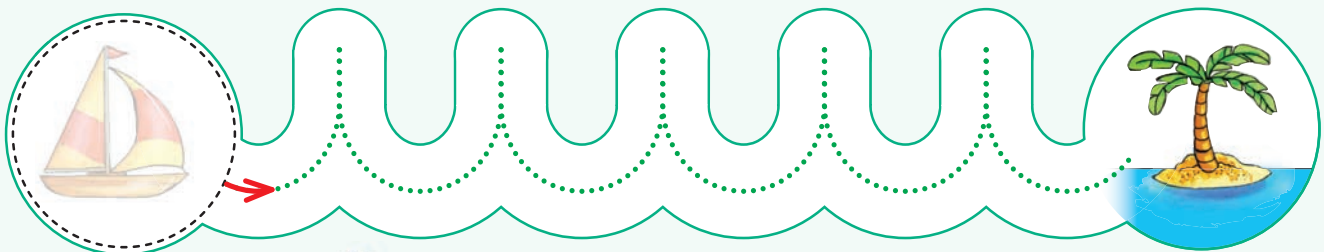

For extra practise, let learners trace over their lines a few times using different colours.



Let's do

Paste in a star sticker to show what you like to do at school.

Paste the stickers in the correct spaces.

I like to:

paint



draw



walk with a friend



read a story



count

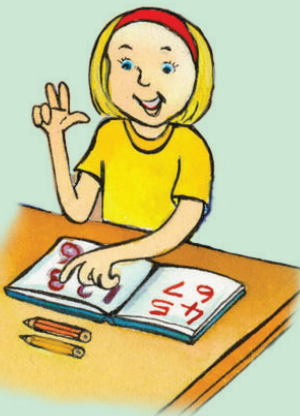

cut out pictures





Let's write

Draw a picture of what you like to do at school.



My name is:



# My body



Let's talk

Look at the picture and talk about what the children are doing.

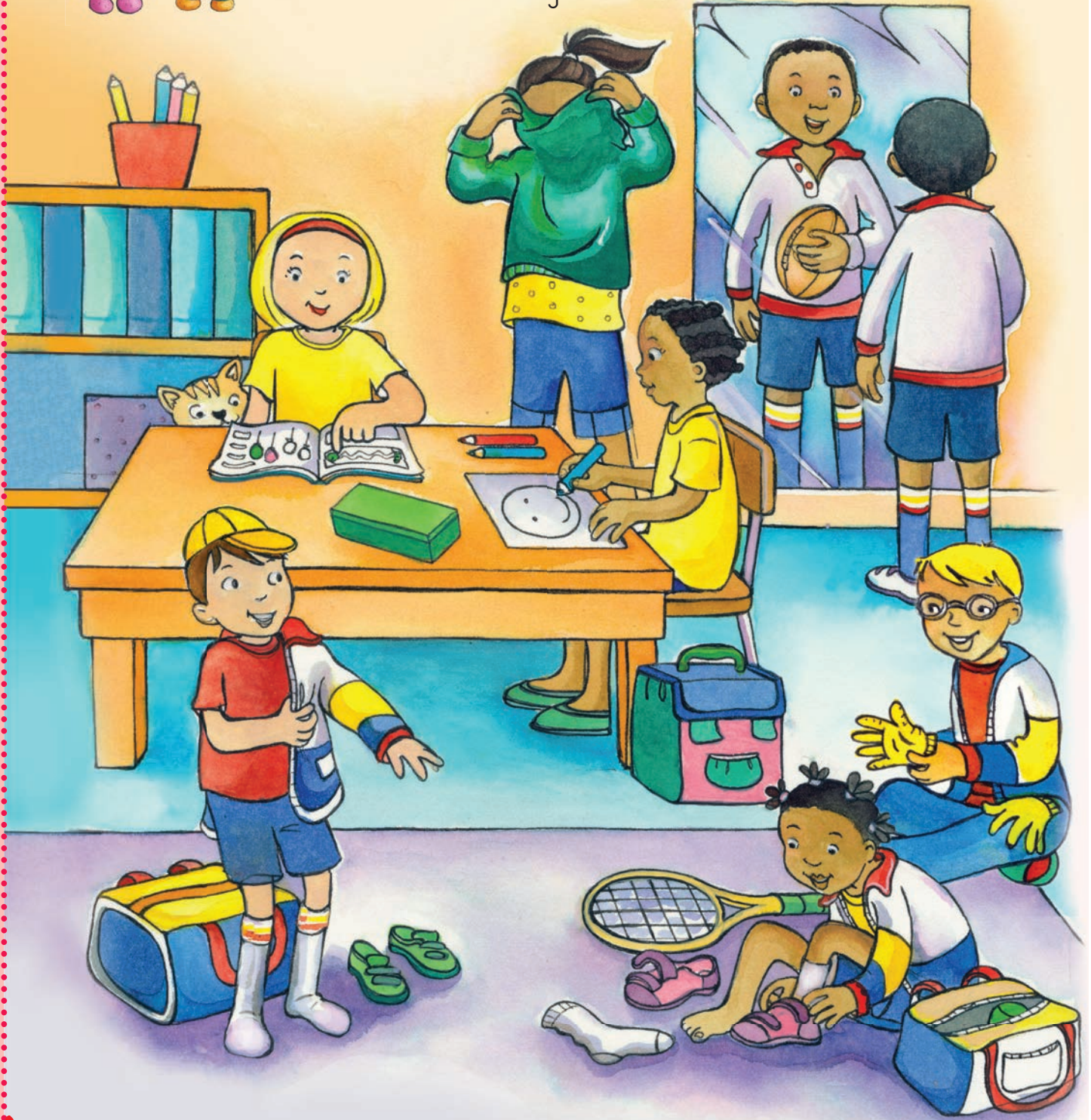



Paste the stickers in the correct spaces.

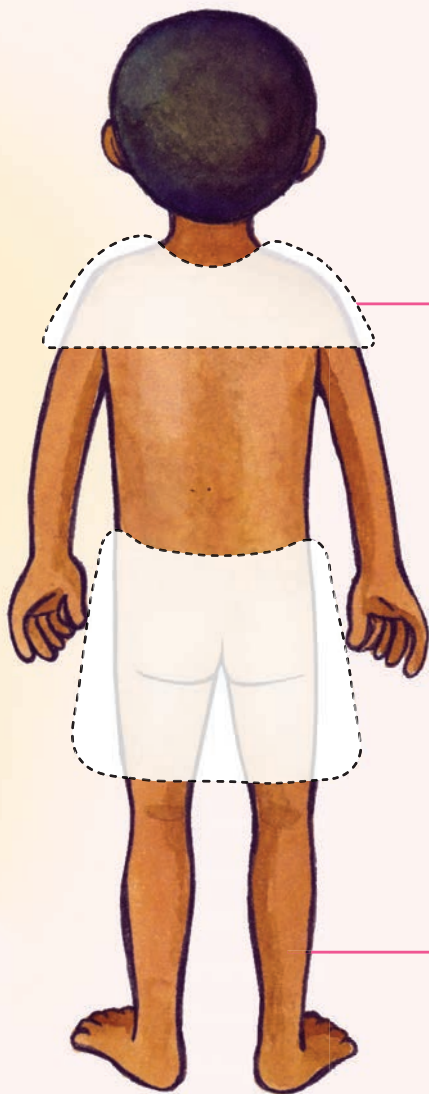

head

shoulders

arm

hand

knee

leg

foot

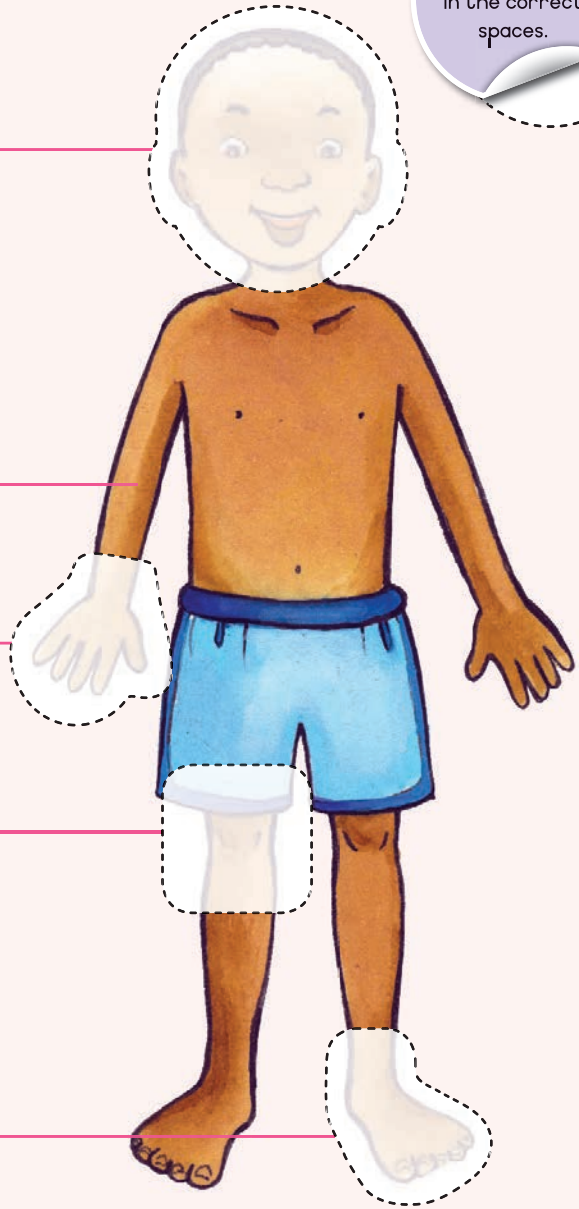

My name is:



Let's talk

Point to your head, shoulders, knees and toes.

Now point to them in the picture.

What body parts do you have one of?

What body parts do you have two of?

Large empty rectangular box for writing answers.

TEACHER: Sign

Blank box for teacher's signature.

Date

Blank box for the date.





Let's write

Point to your head, arms, legs and body. Draw yourself.

Write your name and clap the beat.



My name is:

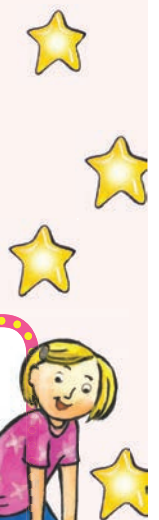

3.2



Let's write

Cut out and then paste in the arms and legs to complete this picture. Then colour in your picture.

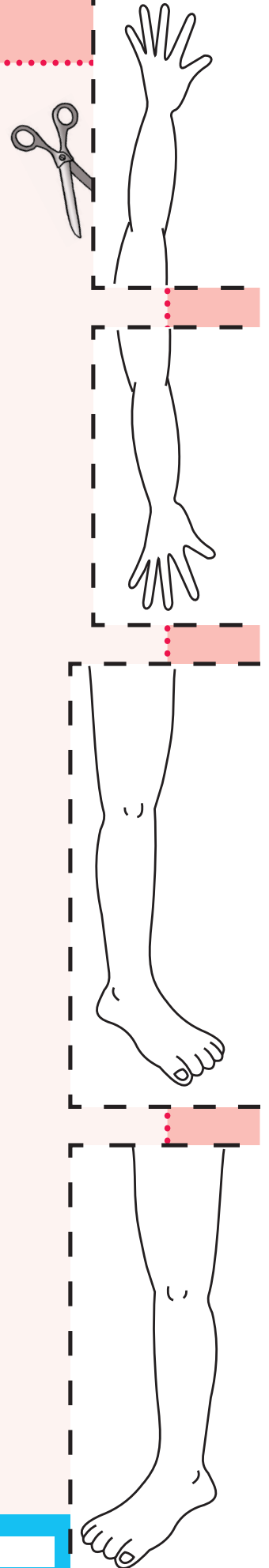
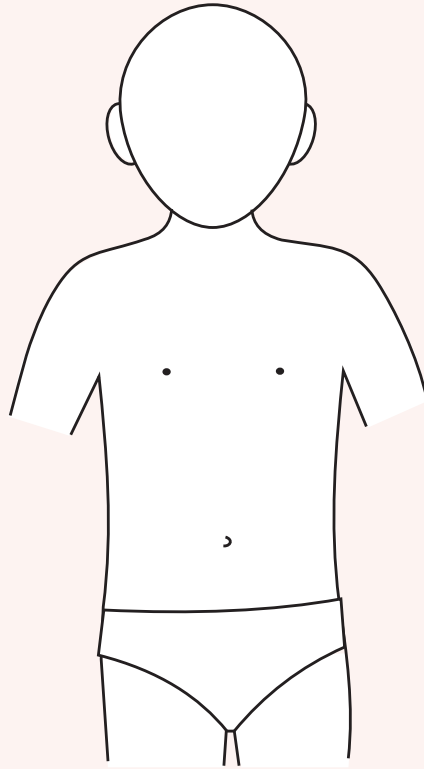

Let's sing



Heads, shoulders,  
knees and toes,  
knees and toes.  
Heads, shoulders,  
knees and toes,  
knees and toes.  
Eyes and ears and  
mouth and nose.  
Heads, shoulders,  
knees and toes,  
knees and toes.



TEACHER: Sign

Date



Let's do

Stand like the boy and the girl in these pictures.  
Show your right hand and then your left hand.  
Stamp your right foot and then your left foot.

boy



left hand



right hand

back



left foot



right foot

3.4



My name is:

[Empty box for writing a name]

girl



front



right hand



left hand



right foot



left foot

TEACHER: Sign

[Empty box for teacher's signature]

Date

[Empty box for date]



Paste the stickers in the correct spaces.

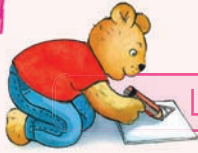

Let's write

Paste in the stickers in the correct places. Then, trace the line with your finger and then with a crayon.



Help the baby find his teddy bear.



Help the dog to find its bone.

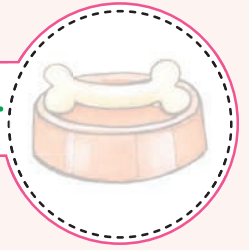
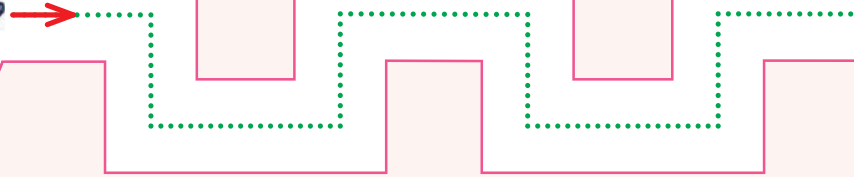

Help Ann to find her book.



Help the baby to crawl to her mother.



For extra practise, let learners trace over their lines a few times using different colours.



Let's write

Trace your weaker hand and then count your fingers.

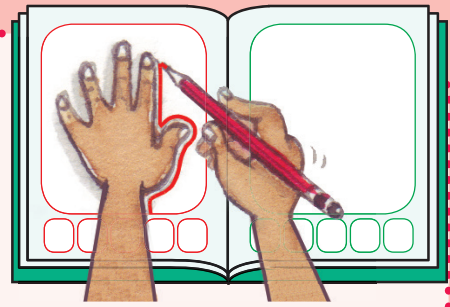

A large, empty rectangular box with rounded corners, outlined in pink, intended for tracing and writing.



Then use some lipstick or paint to fill in your finger prints.

Five empty rounded rectangular boxes arranged horizontally, intended for filling in finger prints.





Let's do

Do what these children are doing.

hands on hips



touch your knees



touch the opposite foot



touch the opposite shoulder

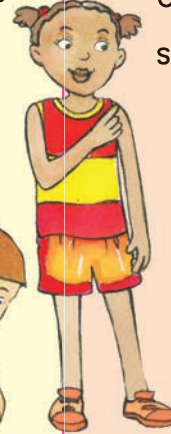

cross your arms



touch your tummy

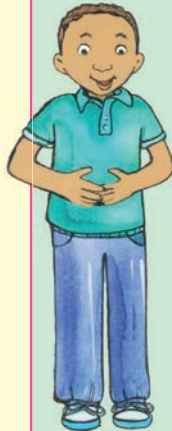

touch your nose



touch your toes



put up two arms



touch your head



touch your shoulders



put out your arm

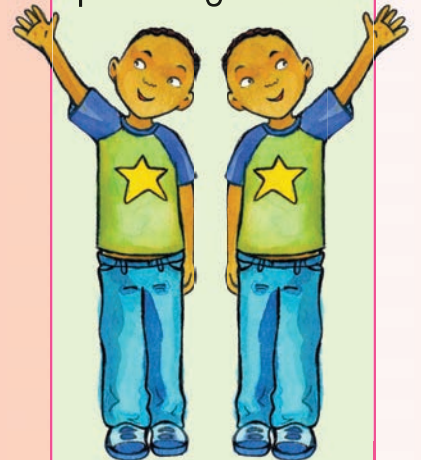





My name is:

Blank space for writing a name.

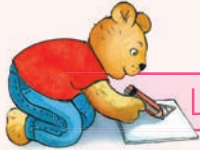

Let's write

Circle the picture that does not belong in each row.  
Tell your friend why this picture does not belong.

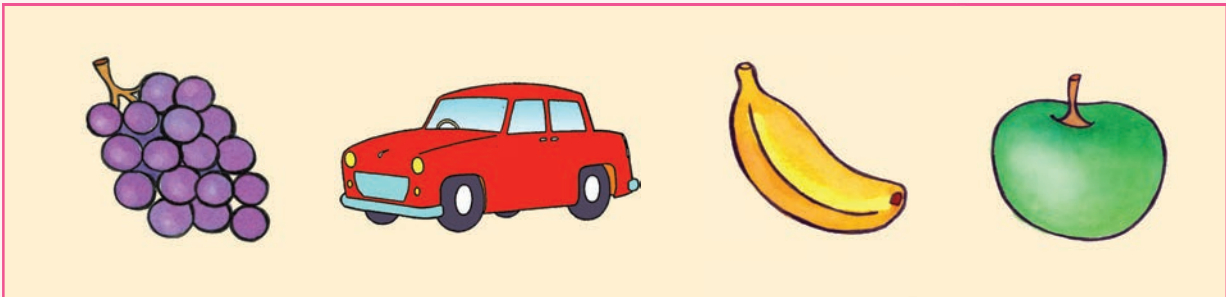
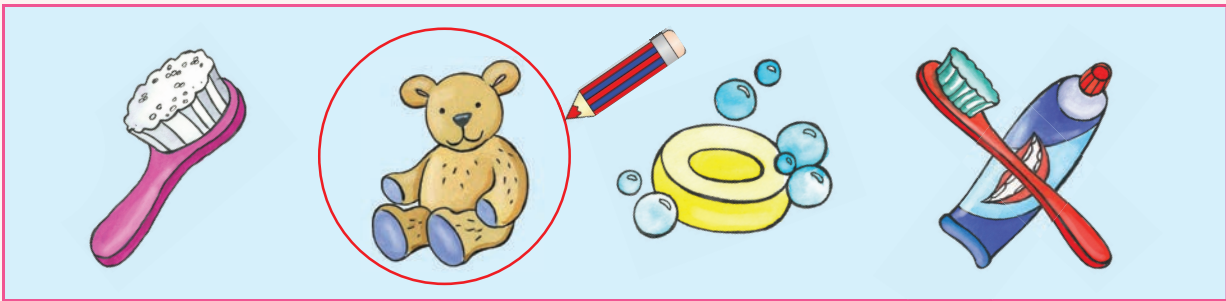

4



# Healthy living



Paste the stickers in the correct spaces.





Let's talk

Look at the picture and say what each child is doing to be clean.

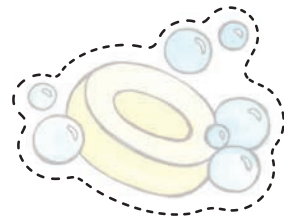

My name is:

TEACHER: Sign

Date



Let's write

Trace the line to find out what these children do to stay clean.

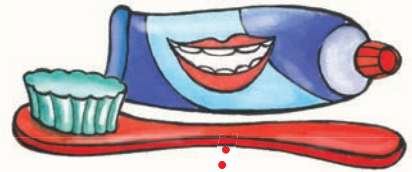
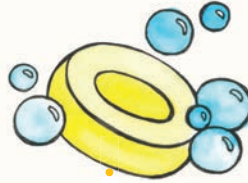

4.2



Let's write

Draw a picture of what you do to stay clean.



My name is:

TEACHER: Sign

Date





My name is:



Let's write

Can you find the toothpaste in this picture?  
 Colour it in red. Trace the lines and count  
 how many other items you can see.

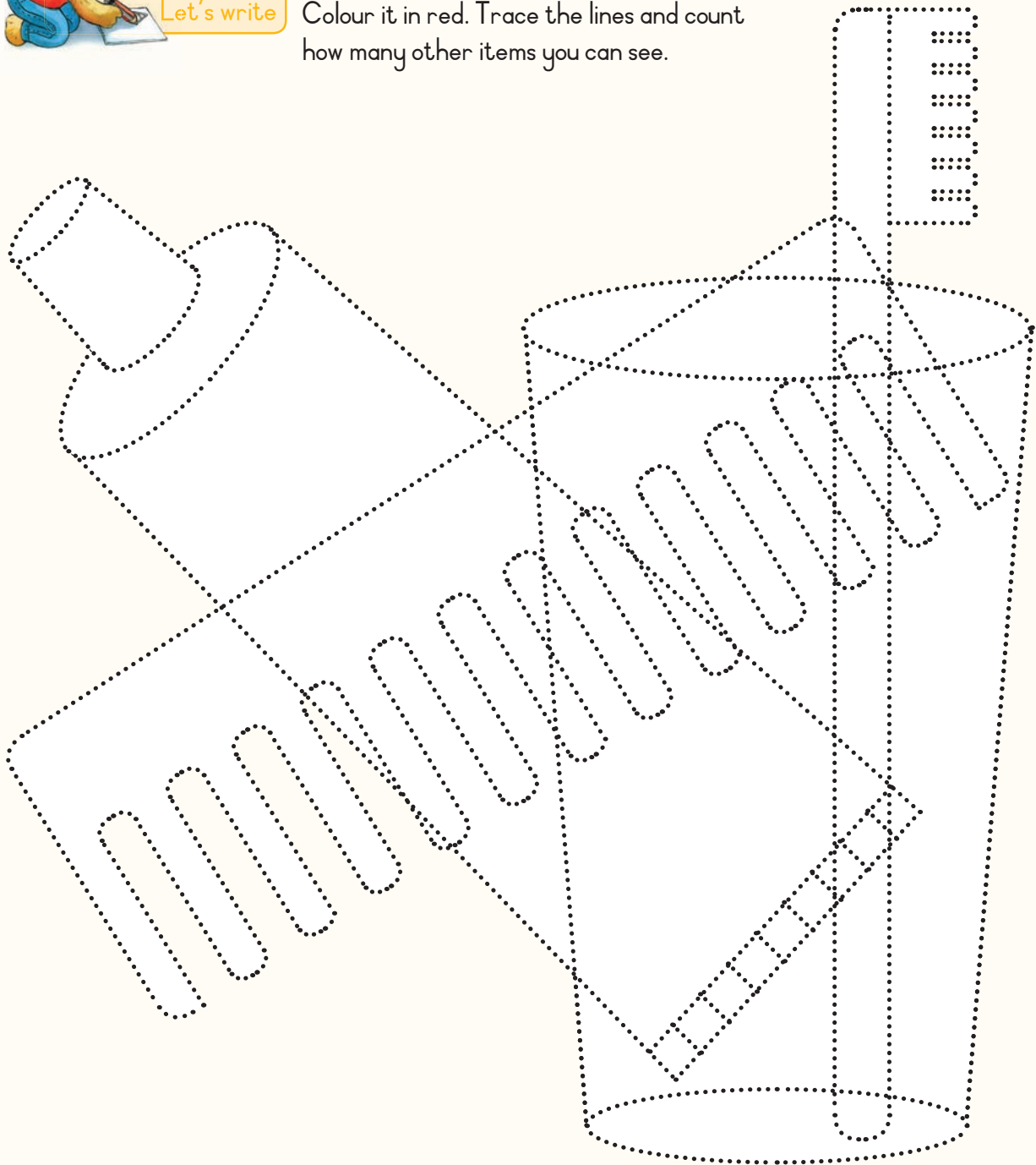



Let's write

Cut out the puzzle and put it together again.





4.5

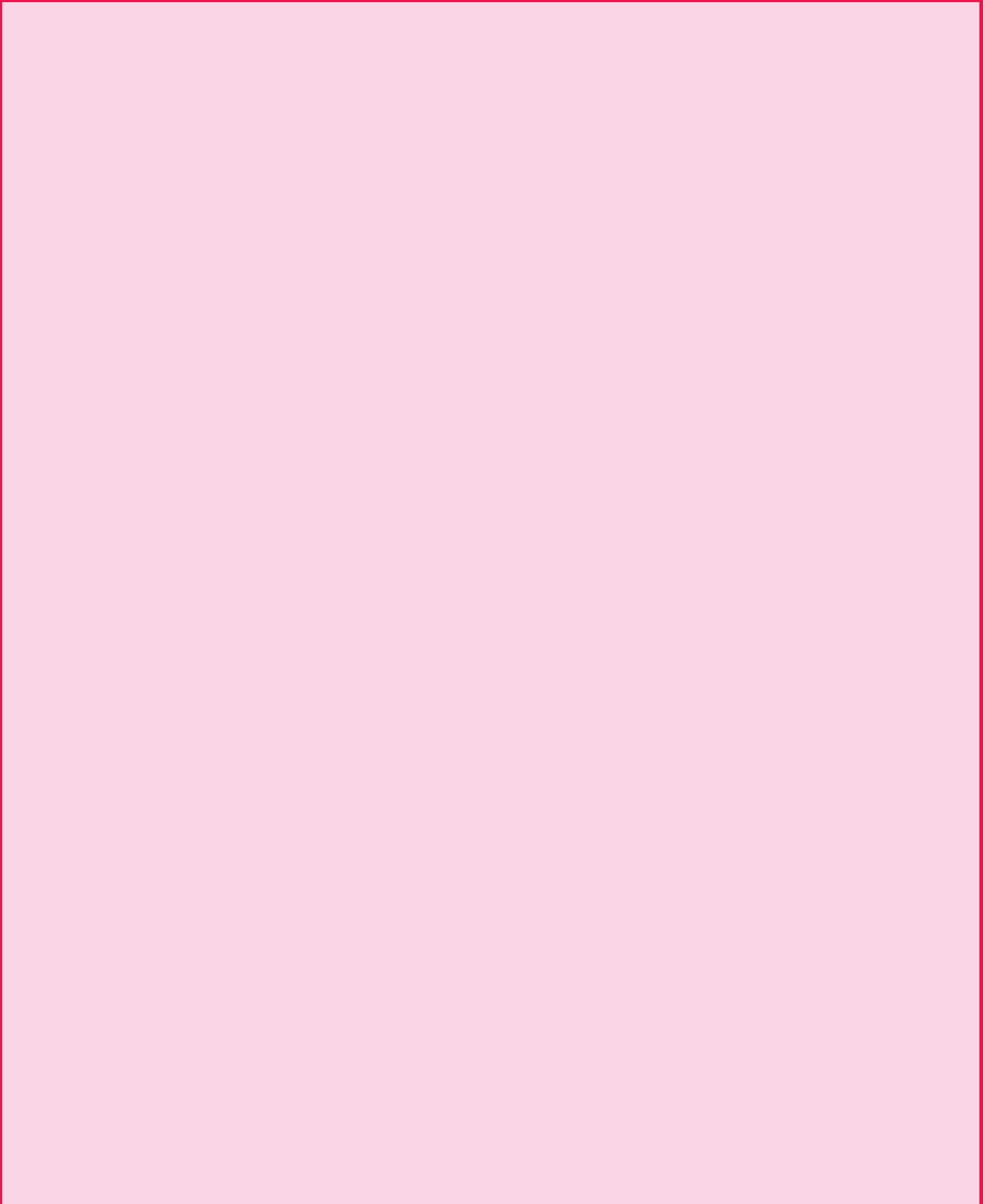





Let's do

Cut out these pictures on the dotted lines and then sequence them.

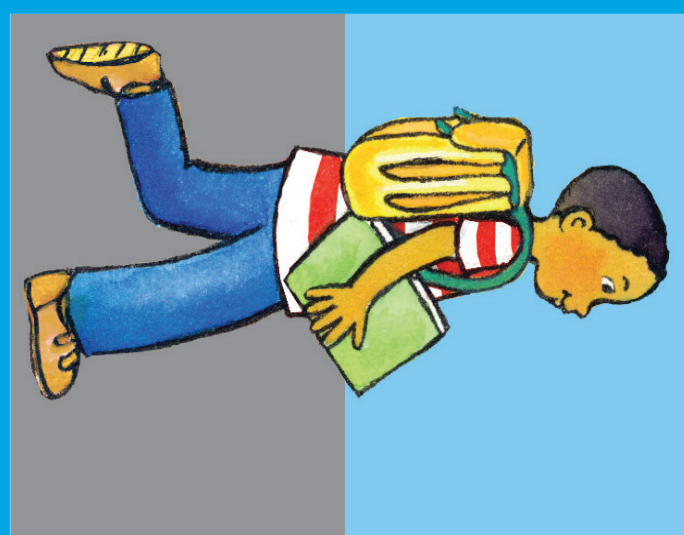

4.7



My name is:



Let's do Sequence these numbers.



4.8









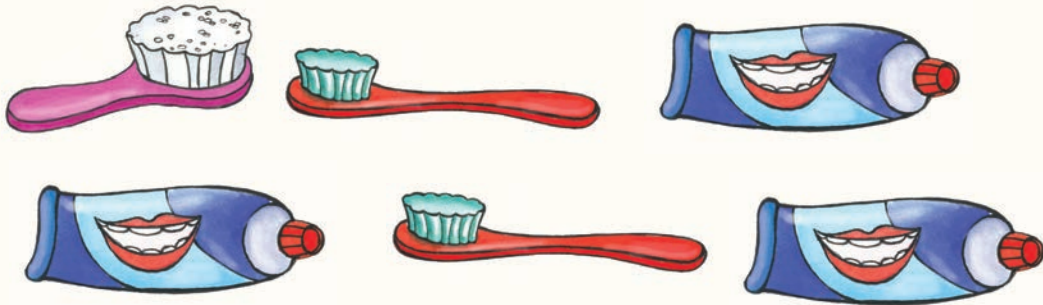

Let's count

Paste the stickers in the correct places.  
Count how many of each item there is.

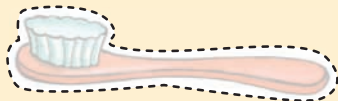
Paste the stickers  
in the correct  
spaces.

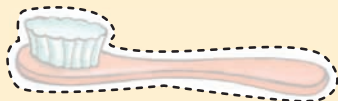

 Practise the number 3.

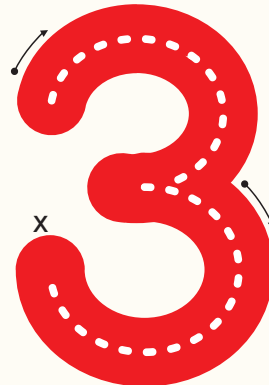
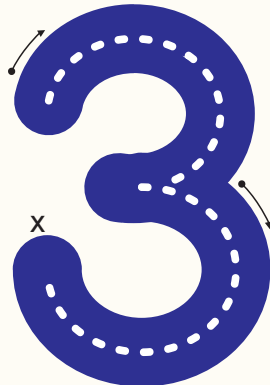
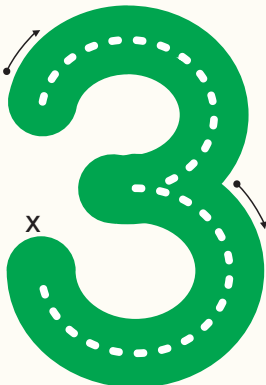

# Friends

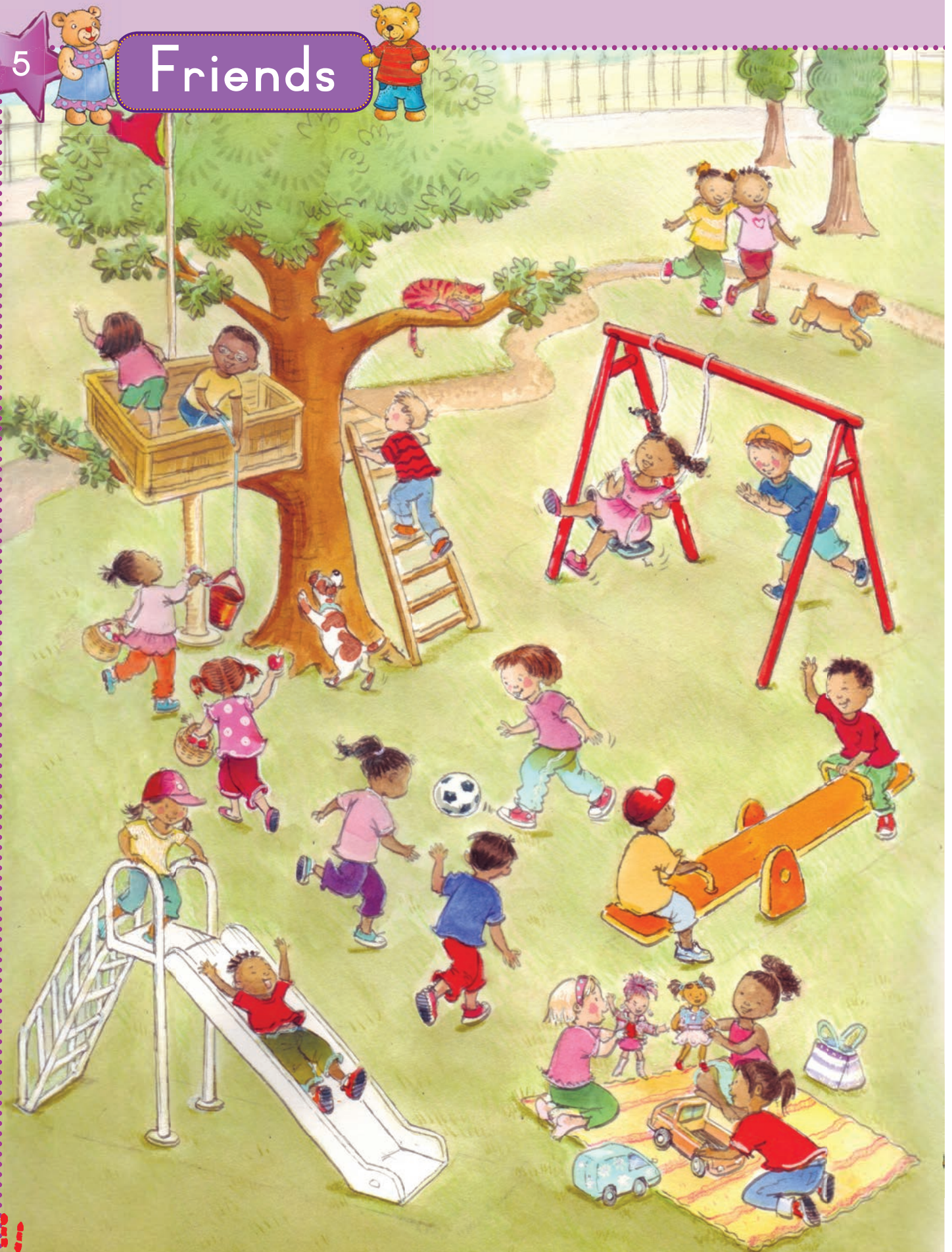

Paste the stickers in the correct spaces.

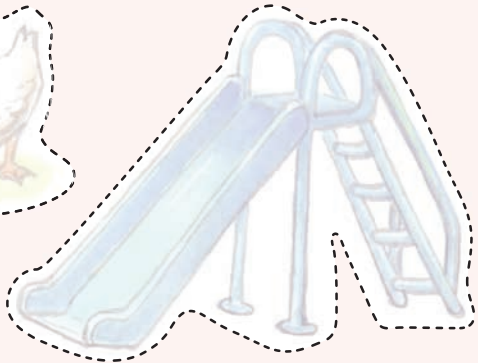
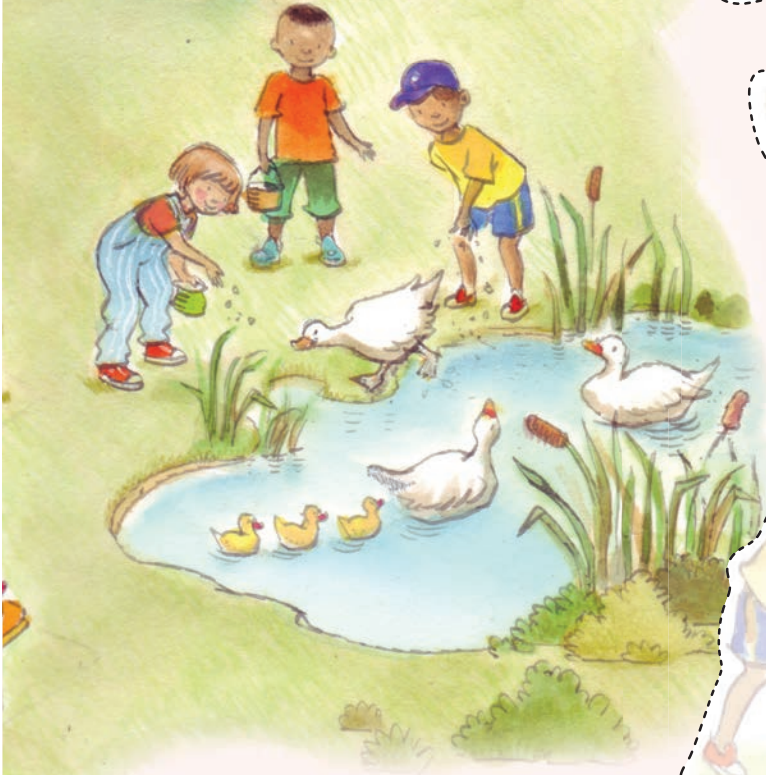

Let's talk

Do you have a good friend?  
What makes a good friend?  
What do you play with your friend?

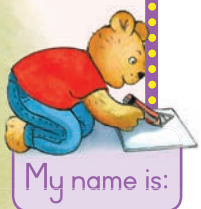

My name is:

A large rectangular box with a decorative border, intended for writing the child's name.



Let's write

Circle the picture that looks the same as the first picture in each row.



Let's write

Trace the shapes and colour them in the same colours as the pictures.

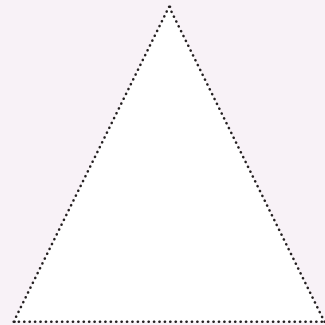
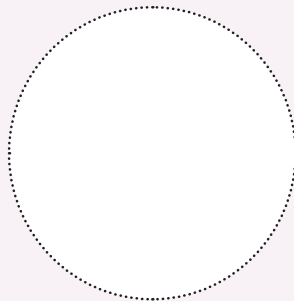
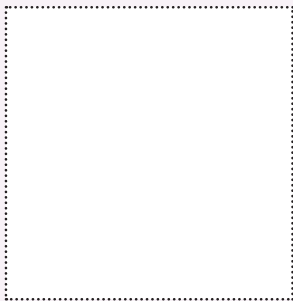



Let's do Do what these children are doing.

sit



jump

skip



run



hop



dance



roll



walk





Let's write

Colour this picture.  
Copy the colours from  
the small picture.





5.4



Let's do

Trace the lines to find their favourite clothes and then colour the balloon to match.

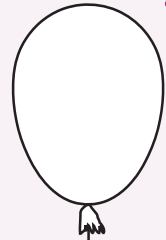
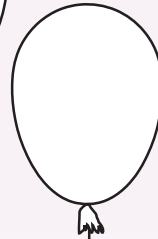
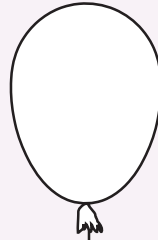
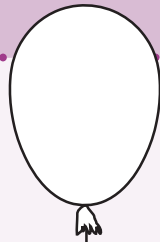

My name is:

A large rectangular box with a dotted border for writing a name.

TEACHER: Sign

\_\_\_\_\_

Date

\_\_\_\_\_



Let's talk

What do you like to do in summer?  
What do you wear when it is hot?

Paste the stickers in the correct spaces.  
Colour 3 apples, 3 bees, 3 tomatoes and the sun.

# It is summer

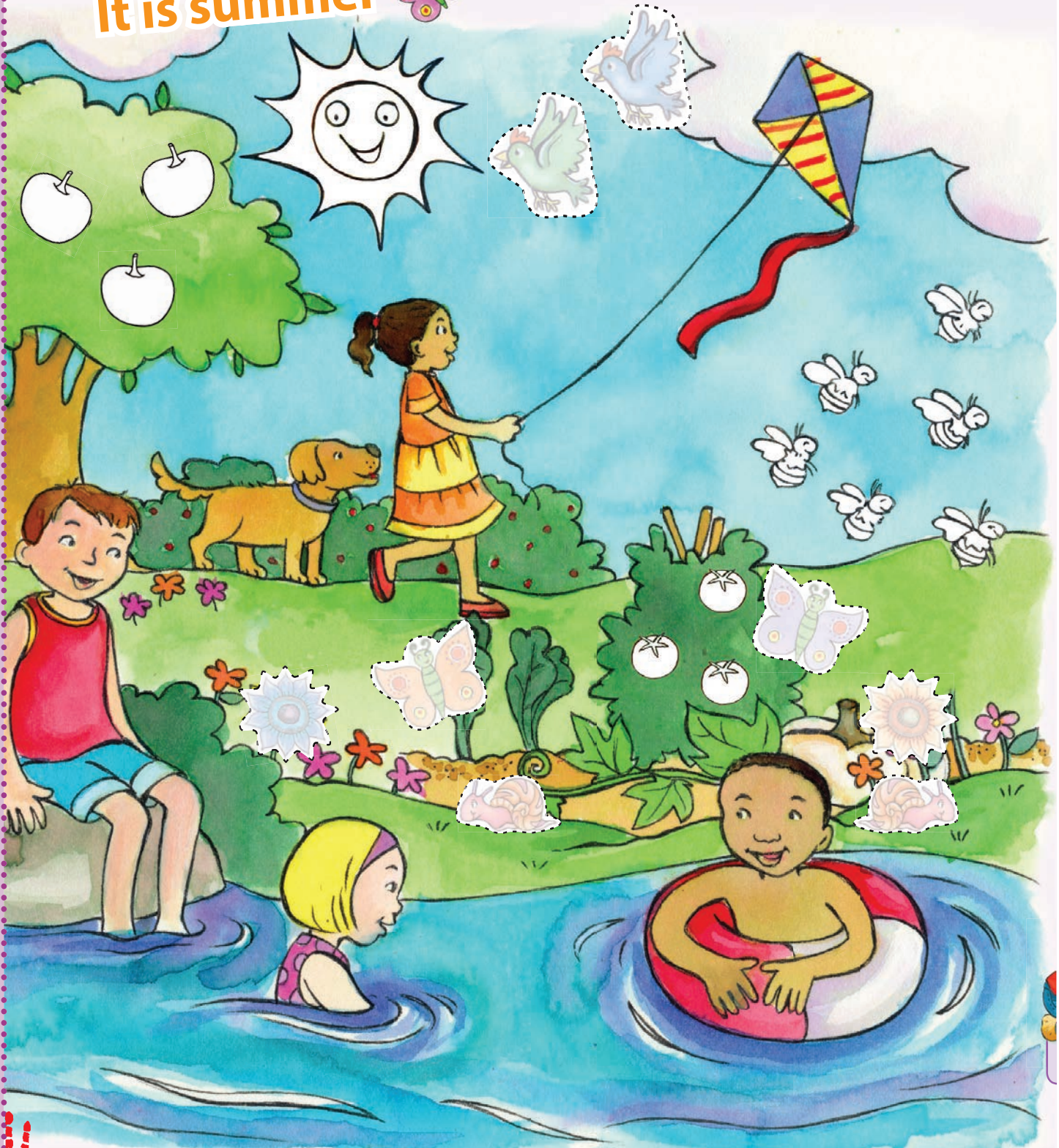

5.6



Let's write

Circle the pictures that show what you like in the summer.



Write your name and clap the beat.



My name is:

TEACHER: Sign

Date



Let's do

Look at the pictures and talk about how the weather is different. Say what the children are doing and what they are wearing.

Paste the stickers in the correct spaces.

hot

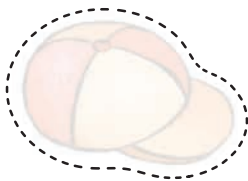
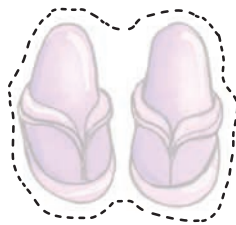
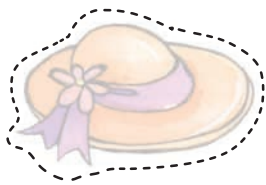



Let's do

Circle the clothes you wear in hot weather in red, and those you wear in cold weather in blue.

cold

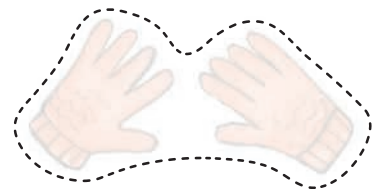



# Cut outs

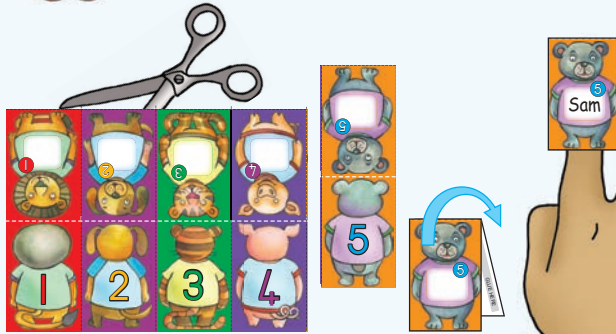

### Finger puppets:

Choose 1 animal and write the first letter of your name on its t-shirt. Then write the first letters of 4 of your friends' names on the others.



### Picture dominoes:

Cut out the cards on the black dotted lines and then match the numbers to the correct pictures.

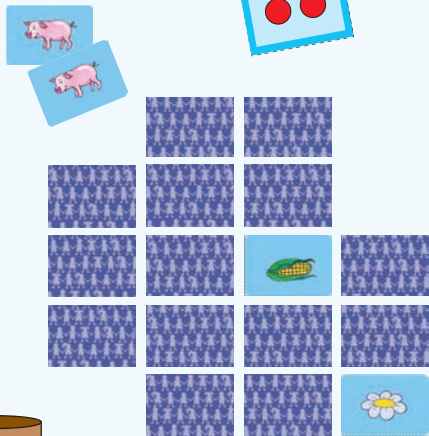

### Memory Game:

Shuffle the cards and pack them out face down on the table. Then, turn 2 cards at a time and see if they match. If they do, put them aside. If they don't put them back. See if you can remember where you put them. The first one to find all the matching pairs is the winner. You can also play snap with these cards.

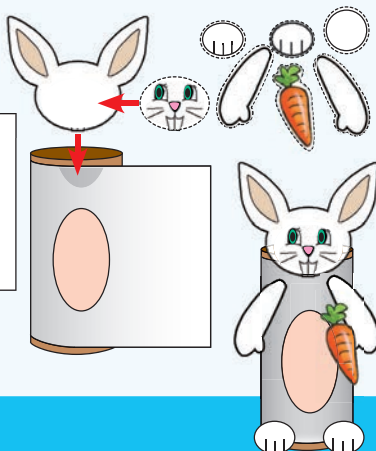
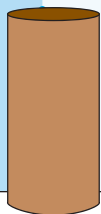

### Toilet roll animals:

Find some empty toilet rolls. Cut out the rectangles and then glue the large rectangular pieces around the toilet rolls to cover the tubes. Now cut out the heads and stick it on the rolls at the top. Use the animal stickers and paste the faces on the heads as you like it. Paste the arms, legs and tail of each animal on the rolls. You can also draw and make your own animals.



Make some zig zag books.  
Cut on the solid lines and  
fold on the dotted lines.



# Numbers

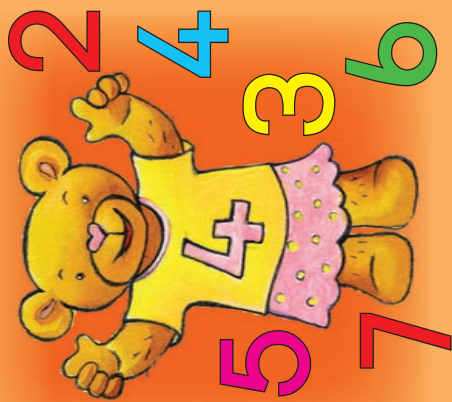

1



one

2

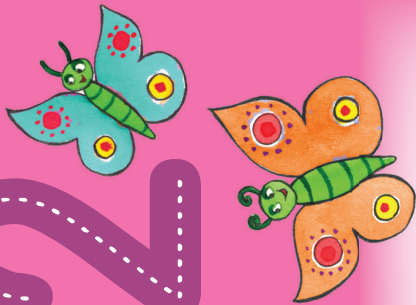

two

3



three

# Pets



dog



cat

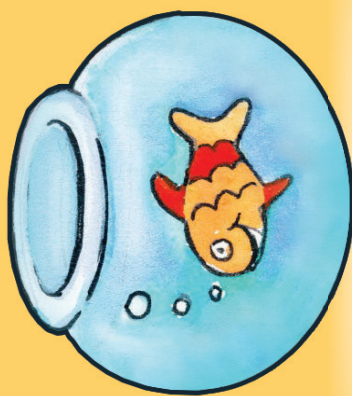

fish

lizard



four

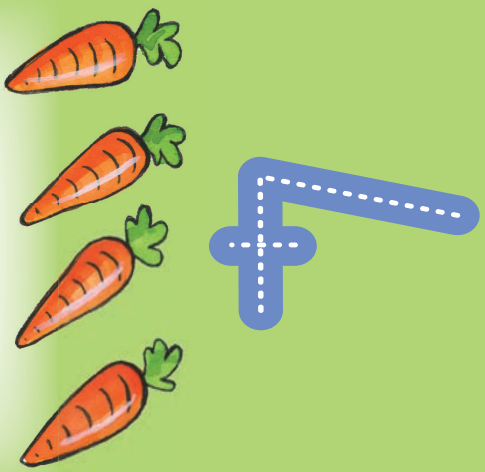

bird

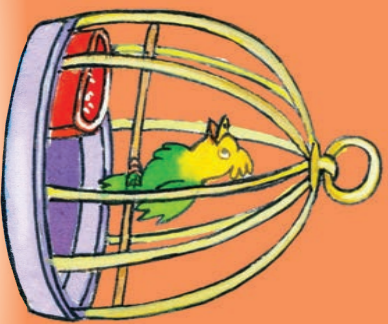

five

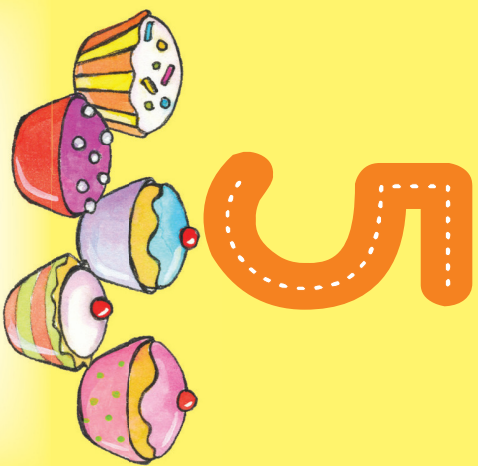

hamster



six

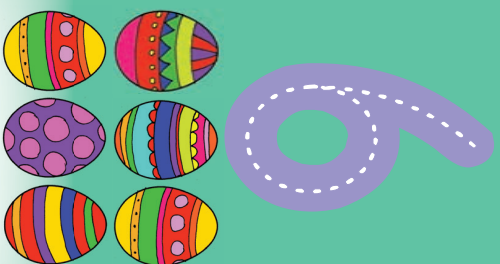

rabbit



seven

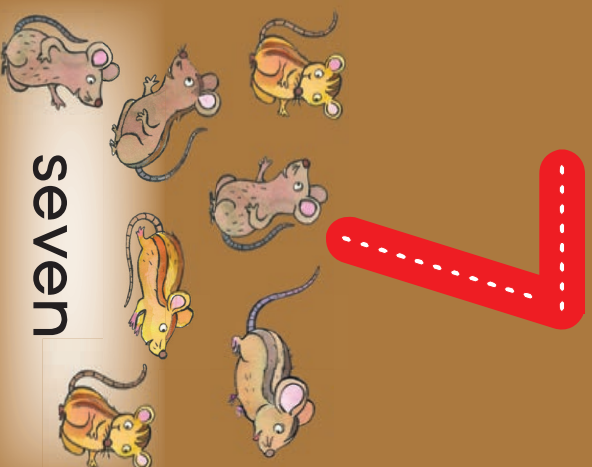





# MY CUT OUTS



Let's do

Cut the page off on the dotted line at the top and then glue the page to the back cover to make a pocket. Keep your cut outs here so that they don't get lost.

GLUE HERE

GLUE HERE

GLUE HERE

GLUE HERE

FOLD

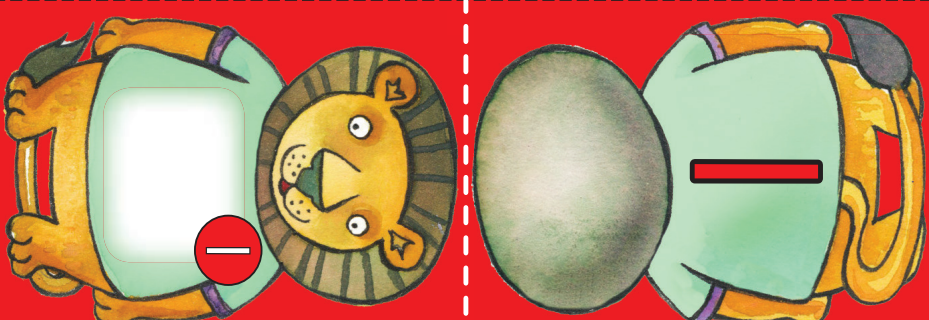
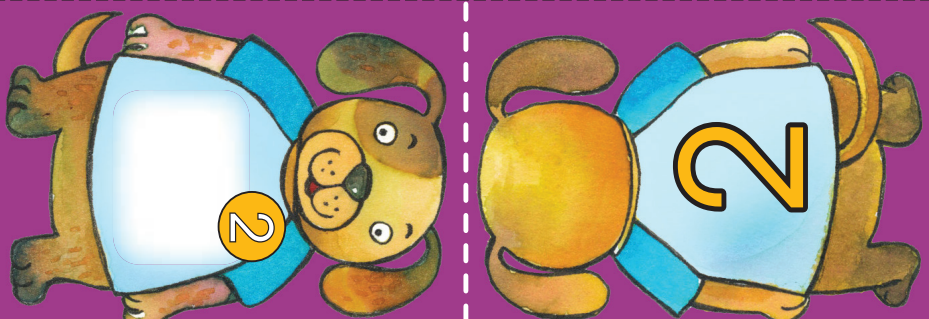
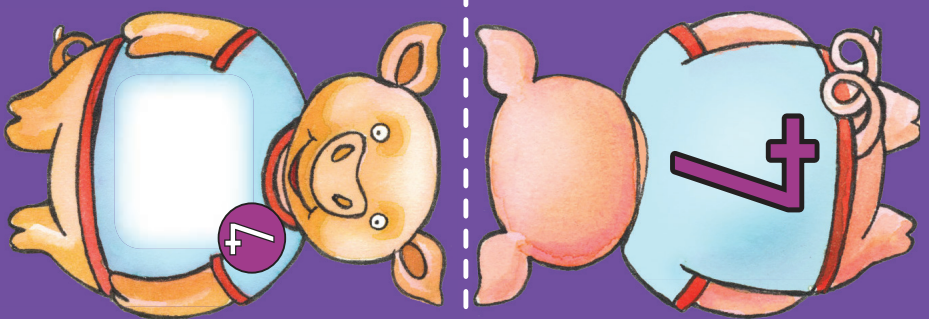
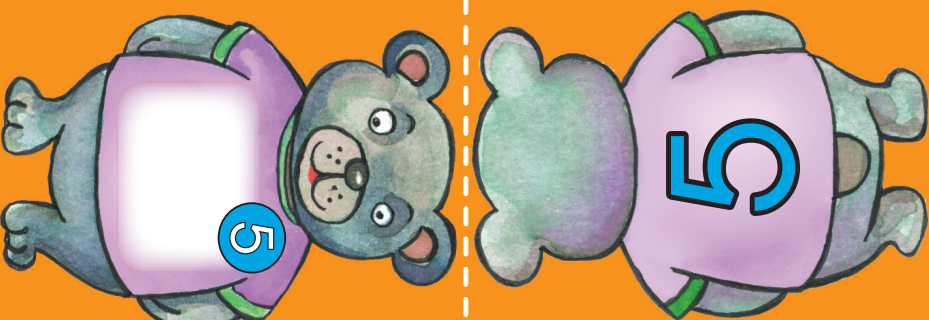

- 0
- 1
- 2
- 3
- 4
- 5
- 6
- 7
- 8
- 9
- 10
- 11
- 12
- 13
- 14
- 15
- 16
- 17
- 18
- 19
- 20
- 21
- 22
- 23
- 24
- 25
- 26
- 27
- 28
- 29

a b c d e f g h i j k l m n o p q r s t u v w x y z

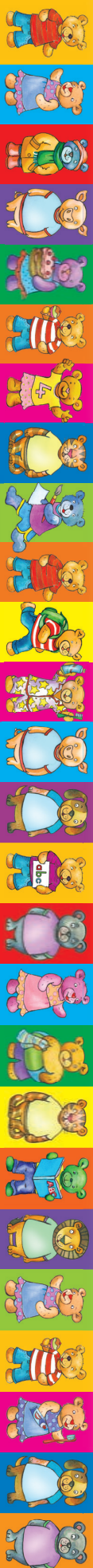

0	a	bear
1	b	beaver
2	c	cat
3	d	dog
4	e	elephant
5	f	fox
6	g	giraffe
7	h	hippo
8	i	iguana
9	j	jackal
10	k	koala
11	l	lion
12	m	monkey
13	n	narwhal
14	o	otter
15	p	panda
16	q	quail
17	r	rabbit
18	s	snake
19	t	turtle
20	u	unicorn
21	v	vulture
22	w	walrus
23	x	x-ray fish
24	y	yak
25	z	zebra

GLUE HERE

GLUE HERE

GLUE HERE

GLUE HERE

GLUE HERE

GLUE HERE

GLUE HERE

GLUE HERE

GLUE HERE

GLUE HERE



1

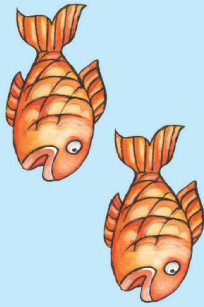
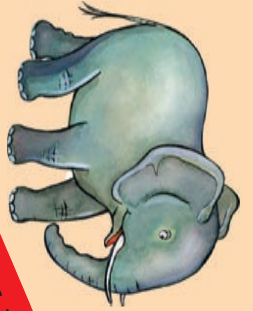

2

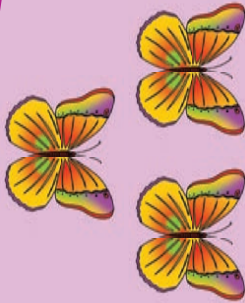
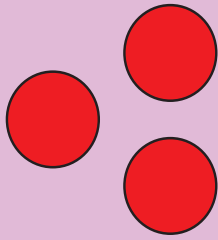

3

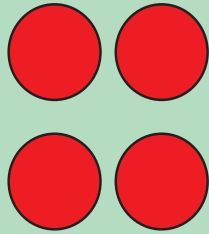

4

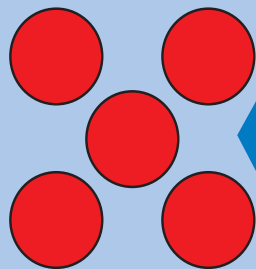
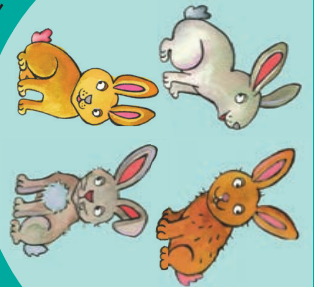

5





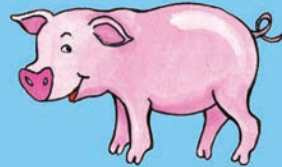
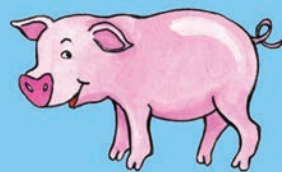

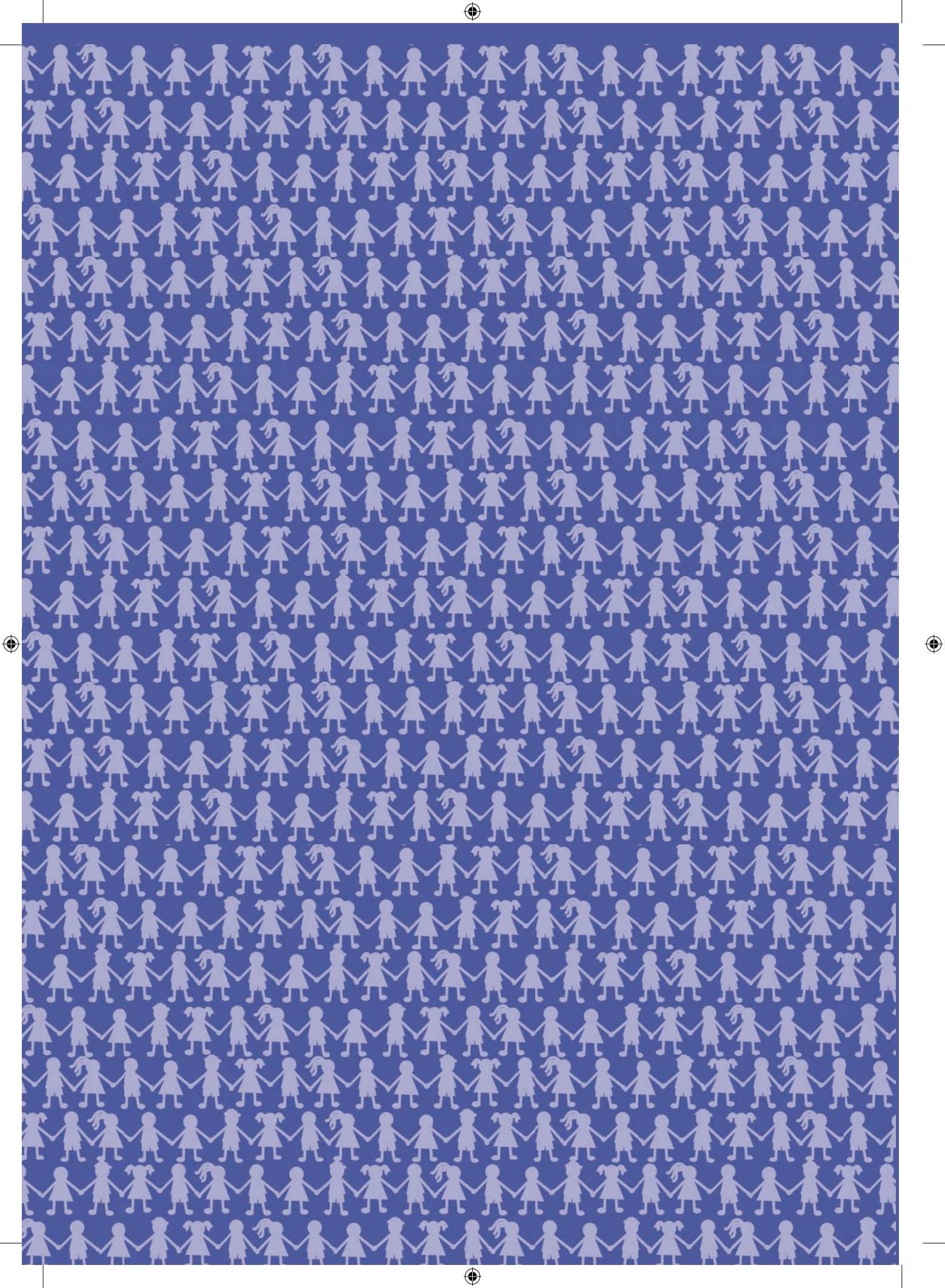



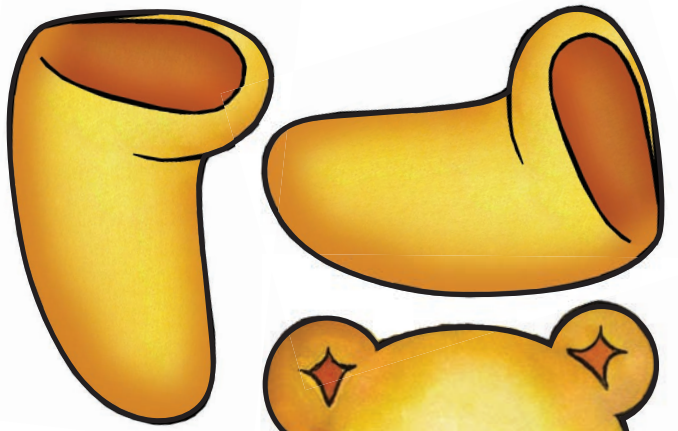
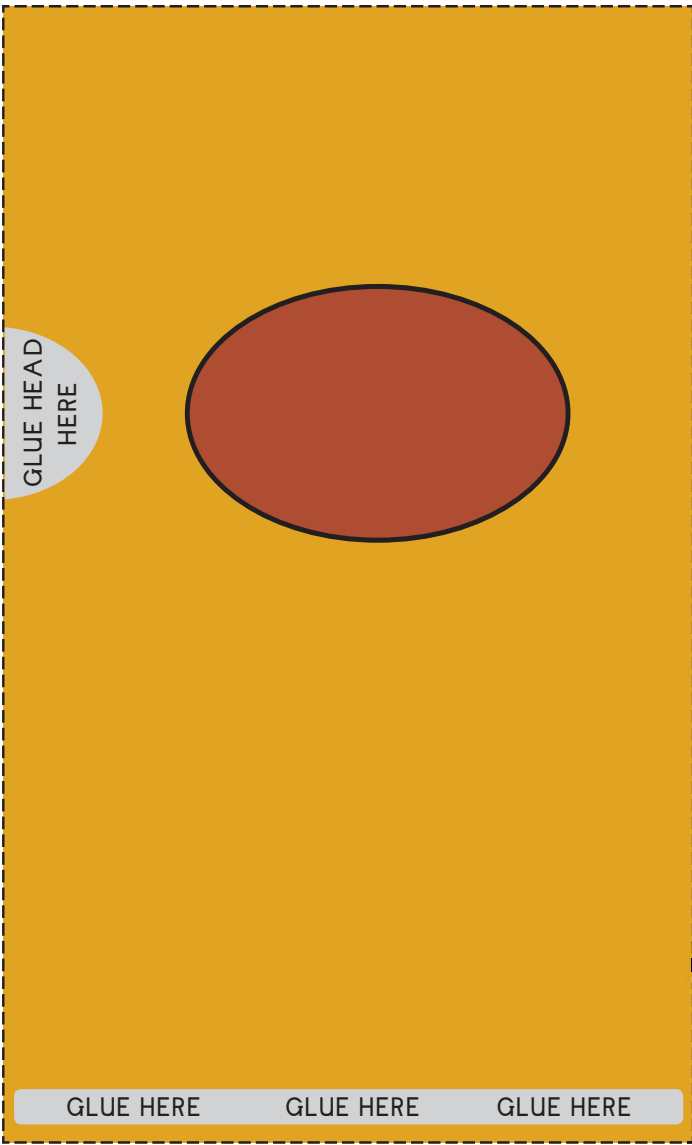

TEDDY BEAR

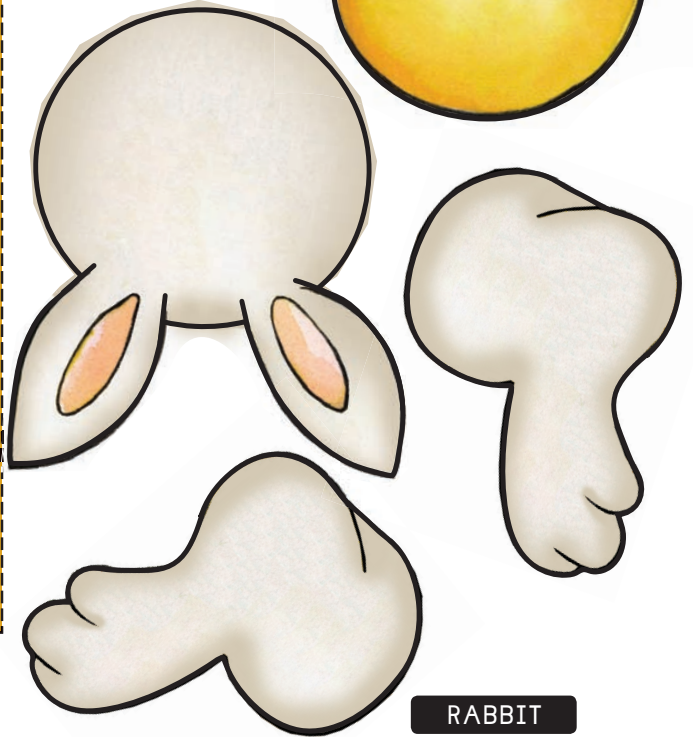

RABBIT

